



**A.Lanfranco  
& Associates Inc.**

Environmental Consultants

Prepared for

**METRO VANCOUVER**

**Metrotower III**

**4515 Central Boulevard  
Burnaby, BC V5H 0C6**

**Waste-to-Energy Facility**

**Emissions Test Report**

**First Quarter 2024 Survey**

**Operational Certificate 107051**

**Prepared by Mr. Shawn Harrington**

**Issued: March 7, 2024**

## **CERTIFICATION**

The field monitoring for this survey was conducted by certified stack test technicians as required by the British Columbia Ministry of Environment (BC MOE) Field Sampling Manual.

The field crew consisted of:

Mr. J. Gibbs (certified), Mr. D. Sampson (certified), Mr. J. Ching (certified), Mr. L. Forrer (certified), Mr. C. De La O, Mr. S. Verby and Mr B. Lester.

The report was prepared by Mr. S. Harrington using reporting principles and guidelines generally acceptable to Metro Vancouver (MV).

The field crew and A. Lanfranco and Associates Inc. certify that the test methods used were BC MOE/MV approved reference methods for the parameters investigated.

Report reviewed on March 7, 2024 by:



Mr. Mark Lanfranco, CST  
President | Owner

---

## TEST PROGRAM ORGANIZATION

**Primary Stakeholders:**

Mr. Brent Kirkpatrick  
Metro Vancouver  
Lead Senior Engineer  
Email: [brent.kirkpatrick@metrovancover.org](mailto:brent.kirkpatrick@metrovancover.org)  
Tel: (604) 451-6623

Ms. Nicole Victor  
Covanta Burnaby Renewable Energy  
Facility Manager  
Email: [nvictor@covanta.com](mailto:nvictor@covanta.com)  
Tel: (604) 521-1025 ext.211

**Project Manager:**

Mr. Mark Lanfranco  
President | Owner  
A. Lanfranco and Associates Inc.  
101 – 9488 189 St  
Surrey, BC Canada V4N 4W7  
Tel: (604) 881-2582  
Email: [mark.lanfranco@alanfranco.com](mailto:mark.lanfranco@alanfranco.com)

**Sampling Crew:**

Mr. B. Lester – A. Lanfranco and Associates Inc.  
Mr. D. Sampson - A. Lanfranco and Associates Inc.  
Mr. J. Gibbs - A. Lanfranco and Associates Inc.  
Mr. L. Forrer - A. Lanfranco and Associates Inc.  
Mr. C. De La O – A. Lanfranco and Associates Inc.  
Mr. J. Ching – A. Lanfranco and Associates Inc.  
Mr. S. Verby – A. Lanfranco and Associates Inc.

---

## Table of Contents

|  |           |
|--|-----------|
| <b>TEST PROGRAM ORGANIZATION</b>           | <b>2</b>  |
| <b>SUMMARY</b>                             | <b>4</b>  |
| <b>1 INTRODUCTION</b>                      | <b>5</b>  |
| <b>2 METHODOLOGY</b>                       | <b>6</b>  |
| <b>2.1 Sampling and Analytical Methods</b> | <b>6</b>  |
| <b>3 DETAILED TEST RESULTS</b>             | <b>12</b> |
| <b>4 DISCUSSION</b>                        | <b>21</b> |

### List of Tables

|   |    |
|---|----|
| Table 1: Summary Comparison of Emissions Test Results with Limits ..... | 4  |
| Table 2: Reference Methods .....  | 6  |
| Table 3: Unit 1 Summary of Emission Test Results .....                  | 12 |
| Table 4: Unit 1 Trace Metals Emissions (OC Class) .....                 | 13 |
| Table 5: Unit 1 Detailed Trace Metals Emissions .....                   | 13 |
| Table 6: Unit 1 - Summary of Operating Data .....                       | 14 |
| Table 8: Unit 2 Summary of Emission Test Results .....                  | 15 |
| Table 9: Unit 2 Trace Metals Emissions (OC Class) .....                 | 16 |
| Table 10: Unit 2 Detailed Trace Metals Emissions .....                  | 16 |
| Table 11: Unit 2 - Summary of Operating Data .....                      | 17 |
| Table 12: Unit 3 Summary of Emission Test Results .....                 | 18 |
| Table 13: Unit 3 Trace Metals Emissions (OC Class) .....                | 19 |
| Table 14: Unit 3 Detailed Trace Metals Emissions .....                  | 19 |
| Table 15: Unit 3 - Summary of Operating Data .....                      | 20 |

### List of Figures

|  |   |
|--|---|
| Figure 1: Example showing circular stack cross section divided ..... | 7 |
| Figure 2: Type S Pitot Tube Manometer Assembly .....                 | 7 |
| Figure 3: Particulate / Trace Metals Sampling Train .....            | 9 |

---

## SUMMARY

The following table displays the emission results from the three units located at Metro Vancouver's Waste-To-Energy Facility (WTEF) as well as the current emission limits as defined by the Operational Certificate (OC) issued by BC Ministry of Environment & Climate Change Strategy. This compliance survey represents the first quarter of 2024.

**Table 1: Summary Comparison of Emissions Test Results with Limits**

| Parameter   | Limit        | Unit 1          | Unit 2          | Unit 3          | Facility Average |
|---|--------------|-----------------|-----------------|-----------------|------------------|
| <b>Test Date</b>  |              | Feb.12-13, 2024 | Feb.13-14, 2024 | Feb.14-15, 2024 |                  |
| <b>Particulate</b> (mg/Sm <sup>3</sup> @ 11% O <sub>2</sub> )             | <b>9.0</b>   | 1.37            | 0.59            | 1.72            | <b>1.23</b>      |
| <b>Hydrogen Fluoride</b> (mg/Sm <sup>3</sup> @ 11% O <sub>2</sub> )       | <b>1.0</b>   | 0.03            | 0.04            | 0.02            | <b>0.03</b>      |
| <b>Trace Metals - OC Class</b> (mg/Sm <sup>3</sup> @ 11% O <sub>2</sub> ) |              |                 |                 |                 |                  |
| Lead (Pb)   | -            | 0.0049          | 0.0011          | 0.0023          | <b>0.0028</b>    |
| Arsenic (As)  | -            | 0.0004          | 0.0006          | 0.0003          | <b>0.0005</b>    |
| Chromium (Cr)   | -            | 0.0021          | 0.0052          | 0.0023          | <b>0.0032</b>    |
| <b>OC Class Sum</b> (Pb, As and Cr)                                       | <b>0.064</b> | 0.0074          | 0.0069          | 0.0049          | <b>0.0064</b>    |
| <b>Mercury</b> (mg/Sm <sup>3</sup> @ 11% O <sub>2</sub> )                 | <b>0.020</b> | 0.000052        | 0.000060        | 0.000042        | <b>0.00005</b>   |
| <b>Cadmium</b> (mg/Sm <sup>3</sup> @ 11% O <sub>2</sub> )                 | <b>0.007</b> | 0.000282        | 0.000093        | 0.000131        | <b>0.00017</b>   |

All data is corrected to standard conditions (S) of 20 °C, 101.325 kPa (dry) unless otherwise noted.

The test results are very similar to those from Q4 2023. The variability observed quarter-to-quarter is well within a normal range of outcomes for this operation and is not considered significant.

---

## 1 INTRODUCTION

Metro Vancouver (MV) commissioned an emission survey at the Waste-To-Energy Facility (WTEF) in Burnaby BC, as required by the provincially approved Operational Certificate (OC). Stationary source monitoring is required Quarterly.

The individual sources that were monitored for compliance are identified as Unit 1, Unit 2 and Unit 3 which represent the three distinct processing lines at the WTEF. The three boilers are identified as discharge E300670 in the operational certificate.

The survey included monitoring for: filterable particulate matter, trace metals, mercury (Hg), hydrogen fluoride (HF), ammonia (NH<sub>3</sub>), nitrous oxide (N<sub>2</sub>O) and volatile organic compounds (VOC).

A. Lanfranco and Associates Inc. (ALAA), of Surrey, B.C., conducted the sampling program on behalf of MV. The sampling program consisted of, but was not limited to, the planning, execution, analysis, and reporting of three emission sources located at the WTEF.

This report includes a comparison of emission results to limits established in the OC, detailed emission results, a brief outline of methods employed, equipment used, and a discussion of the survey. All supporting data and appendices are presented under separate cover.

The appendices for this report, including computer outputs of calculated data, analytical data, field data sheets, calibrations, and professional certifications are issued separately.

## 2 METHODOLOGY

All services provided by A. Lanfranco and Associates Inc. were conducted in accordance with approved reference methods as issued by:

- Metro Vancouver (MV)
- BC Ministry of Environment & Climate Change Strategy (BC MOE)
- Environment Canada (EC)
- US Environmental Protection Agency (EPA)

### 2.1 Sampling and Analytical Methods

The following table lists the test methods used for the different parameters measured. The subsequent paragraphs briefly describe each method.

**Table 2: Reference Methods**

| <u>Parameter</u>  | <u>Reference Method</u>   |
|---|---|
| Sample and Velocity traverse points                     | EPS 1/RM/8 A Determination of Sampling Site and Traverse Points   |
| Velocity and flowrate                                   | EPS 1/RM/8 B Determination of Stack Gas Velocity and Volumetric Flow Rate (Type S Pitot Tube)                               |
| Gas molecular weight (O <sub>2</sub> /CO <sub>2</sub> ) | EPS 1/RM/8 C Determination of Molecular Weight by Gas Analysis  |
| Flue gas Moisture                                       | EPS 1/RM/8 D Determination of Moisture Content  |
| Particulate Matter                                      | EPS 1/RM/8 E Determination of Particulate Matter Emissions from Stationary Sources  |
| Trace Metals with Mercury                               | EPA Method 29 Determination of Metals Emissions from Stationary Sources   |
| Hydrogen Fluoride (HF)                                  | EPS1/RM/1 Reference Method for Source Testing: Measurement of Releases of Gaseous Hydrogen Chloride from Stationary Sources |
| Nitrous Oxide (N <sub>2</sub> O)                        | N/A   |
| Ammonia   | EPA Method CTM 027 Procedure For Collection and Analysis of Ammonia in Stationary Sources                                   |
| Volatile Organic Compounds (VOC)                        | EPA Method TO-15 Determination of Volatile Organic Compounds in Air   |

**Sampling Site and Traverse Points**

This method is designed to aid in the representative measurement of pollutant emissions and/or total volumetric flow rate from a stationary source. A measurement site where the effluent stream is flowing in a known direction is selected, and the cross-section of the stack is divided into a number of equal areas. Traverse points are then located within each of these equal areas.

Primary: EPS 1/RM/8 Method A  
 Supporting: EPA Method 1

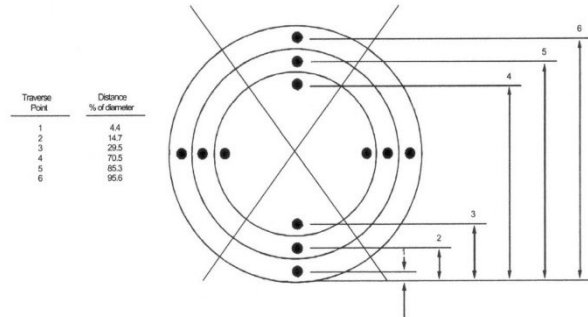
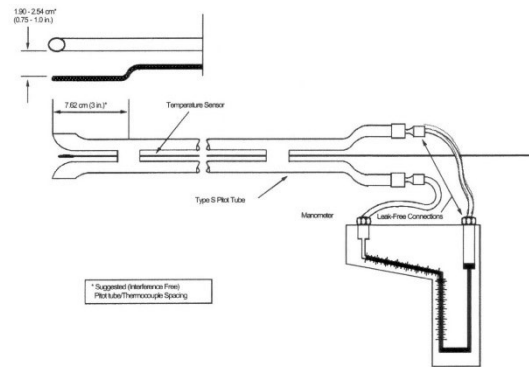

**Figure 1: Example showing circular stack cross section divided**

**Stack Gas Velocity and Volumetric Flow Rate**

The average gas velocity in a stack or duct is determined from the gas density and from the measurement of velocity pressure with an S-type pitot tube. A standard pitot tube may be used where plugging of the tube openings due to particulate matter and/or moisture is not likely to occur. Stack gas volumetric flow rate is determined from measurements of stack gas velocity, temperature, absolute pressure, dry gas composition, moisture content, and stack diameter.

Primary: EPS 1/RM/8 Method B  
 Supporting: EPA Method 2



**Figure 2: Type S Pitot Tube Manometer Assembly**



---

Molecular Weight by Gas Analysis

Primary: EPS 1/RM/8 Method C  
Supporting: EPA Method 3

An integrated or grab sample is extracted from a single point in the gas stream and analyzed for its components using a Fyrite analyzer, a gas chromatograph, or calibrated continuous analyzers.

Moisture Content

Primary: EPS 1/RM/8 Method D  
Supporting: EPA Method 4

A gas sample is extracted from a single point in the enclosed gas stream being sampled. The moisture is condensed, and its weight measured. This weight, together with the volume of gas sampled, enables the stack gas moisture content to be calculated.

Particulate Matter

Primary: EPS 1/RM/8 Method E  
Supporting: EPA Method 5

Particulate matter is withdrawn isokinetically from a number of sampling or traverse points in an enclosed gas stream. The particulate sample is collected in the nozzle, probe, and on a glass fibre filter, all maintained at a temperature of  $120 \pm 14^{\circ}\text{C}$  or such other temperature as is necessary to prevent blinding of the filter from condensation. The particulate weight is determined gravimetrically after removal of uncombined water. Simultaneous determinations of the gas stream moisture content, velocity, temperature, and molecular weight allow calculations of the particulate concentration and the particulate mass emission or release rate to be made.

Trace Metal

Primary: EPA Method 29 (modified)

This method is used in conjunction with the above Method 5. A stack sample is withdrawn isokinetically from the source. Particulate emissions are collected in the probe and on a heated filter, and gaseous emissions are then collected in an aqueous acidic solution of hydrogen peroxide (analyzed for all metals including Hg) and an aqueous acidic solution of potassium permanganate (analyzed only for Hg). The recovered samples are digested, and appropriate fractions are analyzed for Hg by cold vapour atomic absorption spectroscopy (CVAAS). The remaining trace metals are analyzed with inductively coupled argon plasma emission spectroscopy (ICAP), atomic absorption spectroscopy (AAS) and graphite furnace atomic absorption spectroscopy (GFAAS). Figure 3 presents the sample train and its configuration.

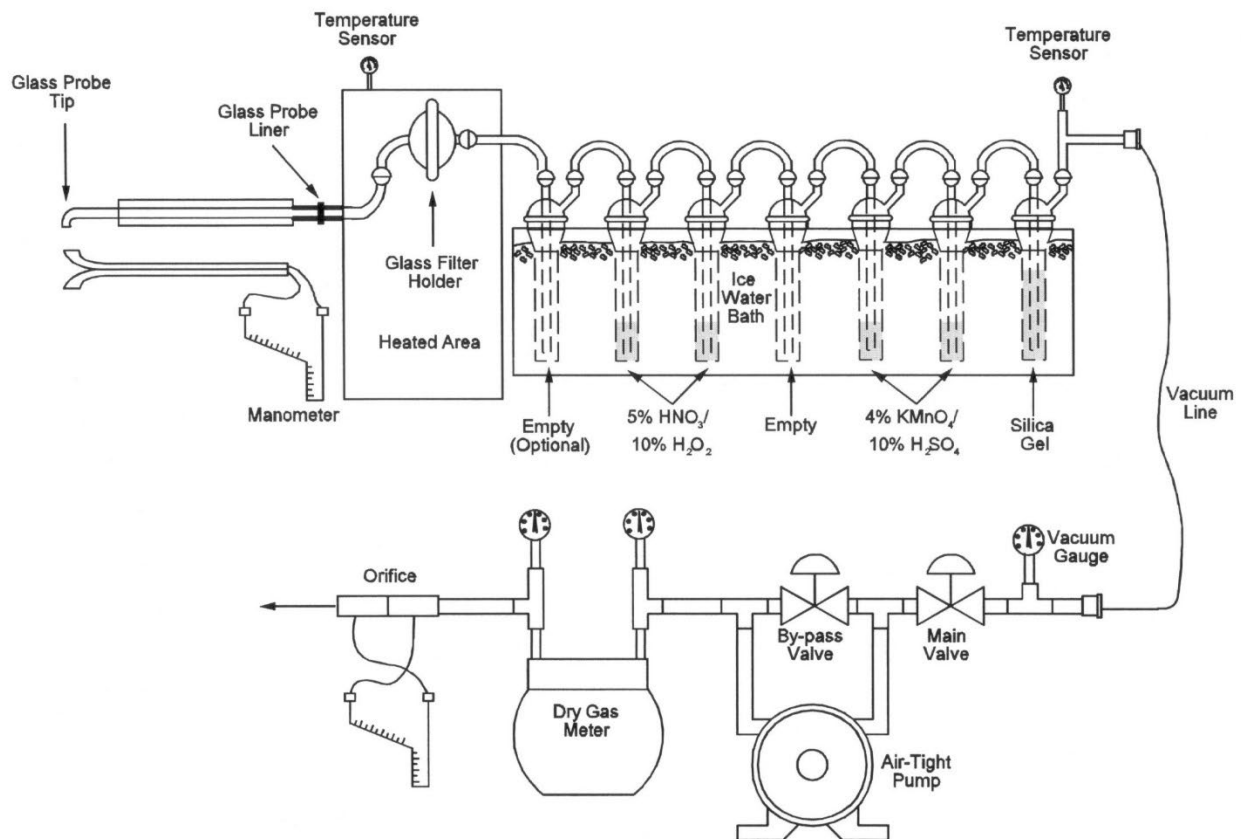

**Figure 3: Particulate / Trace Metals Sampling Train**

---

Hydrogen Fluoride

Primary: EPS 1/RM/1

Supporting: BC Method 7176106 & 7066101

HF is sampled in a four-impinger train consisting of two impingers containing distilled/deionized H<sub>2</sub>O, one empty impinger, and a fourth containing silica gel. A sample of the stack gas is extracted from a single point near the centre of the stack over the sample duration at a constant rate. The collected samples are measured for F by ion chromatography at Element laboratory in Surrey, BC.

N<sub>2</sub>O

Primary: N/A

Three N<sub>2</sub>O samples were collected from each source using Viasensor G200 Medical Grade gas analyser, calibrated to NIST traceable Nitrous Oxide standards. The flue gas was introduced to the G200 after passing through a soda lime filter to remove CO<sub>2</sub>. Multiple readings were taken over a one hour period, these readings were averaged on the analyzer and recorded on the data sheet.

Ammonia

Primary: EPA Method CTM-027

The absorbing solution in the first two impingers is 0.1 N H<sub>2</sub>SO<sub>4</sub> and the triplicate samples were extracted at a constant rate for 60-minute durations. The collected samples are analyzed at Element laboratory in Surrey, BC.

### Method Modifications

Three minor method modifications were instituted for this work.

1. Reagent blanks for metals trains were made to the same volumes as all samples. In other words, exactly 100 ml of the various reagents used to recover samples was NOT done, as some sample components (probe washing for example) required more than 100 ml to adequately clean and rinse the probe. Instead, sample recovery was conducted with however much rinsing was deemed adequate. In the laboratory, the blanks and samples were made up with the appropriate reagent so that all samples and blanks were the same volume.
2. Filter and residue weighing were not conducted with the six-hour interval technique. Instead, the sample filters and beakers were conditioned with cooling and desiccation and then weighed on two separate laboratory scales after 24 hours. Duplicate or triplicate Blank samples were carried through the gravimetric analysis, and the sample results were adjusted with the Blank data to determine the net filter and probe wash residue weight gain. This is the Environment Canada approved modified approach for weighing probe wash residue.
3. For the purposes of calculating a result, all parameters were given the value of  $\frac{1}{2}$  the detection limit when the analysis yielded 'non-detect' results.

All results are expressed using the metric system and corrected to standard conditions of 20 °C and 101.325 kPa, dry gas (unless otherwise noted).

### 3 DETAILED TEST RESULTS

The results of stack emissions were calculated using a “STACK” computer program developed by A. Lanfranco and Associates for BC MOE requirements.

Tables 3-14 present the detailed results of all emissions parameters tested and operational conditions for each of the units. Additional data and the computer outputs can be found in the accompanying Appendices.

**Table 3: Unit 1 Summary of Emission Test Results**

| Parameter  | Run 1         | Run 2         | Run 3         | Average        |
|--|---------------|---------------|---------------|----------------|
| Test Date - Particulate/Metals   | 12-Feb-24     | 13-Feb-24     | 13-Feb-24     |                |
| Test Time - Particulate/Metals   | 12:19 - 14:20 | 09:16 - 11:18 | 11:45 - 13:47 |                |
| Duration - Minutes   | 120           | 120           | 120           |                |
| Test Date - Acid Gases   | 13-Feb-24     | 13-Feb-24     | 13-Feb-24     |                |
| Test Time - Acid Gases   | 09:43-10:43   | 10:52-11:52   | 12:00-13:00   |                |
| Duration - Minutes   | 60            | 60            | 60            |                |
| Stack Temperature (°C)   | 146           | 150           | 152           | 149            |
| Average Gas Velocity (m/s)   | 12.7          | 13.0          | 14.6          | 13.5           |
| Dry Flow Rate (Sm <sup>3</sup> /min)   | 1101          | 1142          | 1283          | 1175           |
| Moisture (Vol. %)  | 15.7          | 13.4          | 12.9          | 14.0           |
| Oxygen (Vol. %)(dry basis)   | 8.79          | 10.1          | 10.2          | 9.69           |
| Carbon Dioxide (Vol. %)(dry basis)   | 10.9          | 9.58          | 9.34          | 9.94           |
| <b>Particulate (mg/Sm<sup>3</sup> @ 11% O<sub>2</sub>)</b>                                 | 1.20          | 1.34          | 1.57          | <b>1.37</b>    |
| <b>Hydrogen Fluoride (mg/Sm<sup>3</sup> @ 11% O<sub>2</sub>)</b>                           | 0.022         | 0.042         | 0.031         | <b>0.032</b>   |
| <b>Ammonia (mg/Sm<sup>3</sup> @ 11% O<sub>2</sub>)</b>                                     | 1.95          | 4.12          | 5.20          | <b>3.75</b>    |
| <b>Nitrous Oxide (mg/Sm<sup>3</sup> @ 11% O<sub>2</sub>)*</b>                              | 0.90          | 3.18          | 1.53          | <b>1.87</b>    |
| <b>Total Hydrocarbons (mg/Sm<sup>3</sup> @ 11% O<sub>2</sub>)</b>                          | 3.44          | 2.52          | 3.57          | <b>3.18</b>    |
| <b>Trace Metals - Operational Certificate List (mg/Sm<sup>3</sup> @ 11% O<sub>2</sub>)</b> |               |               |               |                |
| <b>OC Class (Pb, As and Cr)</b>  | 0.00576       | 0.00878       | 0.00777       | <b>0.00744</b> |
| <b>Aluminum (mg/Sm<sup>3</sup> @ 11% O<sub>2</sub>)</b>                                    | 0.01481       | 0.04606       | 0.02814       | 0.02967        |
| <b>Cadmium (mg/Sm<sup>3</sup> @ 11% O<sub>2</sub>)</b>                                     | 0.00025       | 0.00026       | 0.00033       | 0.00028        |
| <b>Lead (mg/Sm<sup>3</sup> @ 11% O<sub>2</sub>)</b>  | 0.00469       | 0.00518       | 0.00496       | 0.00494        |
| <b>Mercury (mg/Sm<sup>3</sup> @ 11% O<sub>2</sub>)</b>                                     | 0.00004       | 0.00005       | 0.00007       | 0.000052       |
| <b>Phosphorus (mg/Sm<sup>3</sup> @ 11% O<sub>2</sub>)</b>                                  | 0.00308       | 0.00128       | 0.00261       | 0.00233        |
| Isokinetic Variation ( % )   | 104           | 102           | 101           | 102            |

\*N<sub>2</sub>O was sampled on February 13, 2024

All data is corrected to standard conditions (S) of 20 °C, 101.325 kPa (dry) unless otherwise noted.

**Table 4: Unit 1 Trace Metals Emissions (OC Class)**

| <b>Metal</b>    | <b>Test 1</b><br>(mg/m <sup>3</sup> @ 11% O <sub>2</sub> ) | <b>Test 2</b><br>(mg/m <sup>3</sup> @ 11% O <sub>2</sub> ) | <b>Test 3</b><br>(mg/m <sup>3</sup> @ 11% O <sub>2</sub> ) | <b>Average</b><br>(mg/m <sup>3</sup> @ 11% O <sub>2</sub> ) |
|-----------------|--|--|--|---|
| <b>OC Class</b> |  |  |  |   |
| Pb              | 0.00469  | 0.00518  | 0.00496  | 0.00494   |
| As              | 0.00056  | 0.00032  | 0.00029  | 0.00039   |
| Cr              | 0.00052  | 0.00328  | 0.00252  | 0.00210   |
| Sum of OC Class | 0.00576  | 0.00878  | 0.00777  | 0.00744   |
| <b>Other</b>    |  |  |  |   |
| Al              | 0.01481  | 0.04606  | 0.02814  | 0.02967   |
| Cd              | 0.00025  | 0.00026  | 0.00033  | 0.00028   |
| P               | 0.00308  | 0.00128  | 0.00261  | 0.00233   |
| Hg              | 0.00004  | 0.00005  | 0.00007  | 0.00005   |

All data is corrected to standard conditions (S) of 20 °C, 101.325 kPa (dry) unless otherwise noted.

**Table 5: Unit 1 Detailed Trace Metals Emissions**

| <b>Metal</b> | <b>Test 1</b><br>(mg/m <sup>3</sup> @ 11% O <sub>2</sub> ) | <b>Test 2</b><br>(mg/m <sup>3</sup> @ 11% O <sub>2</sub> ) | <b>Test 3</b><br>(mg/m <sup>3</sup> @ 11% O <sub>2</sub> ) | <b>Average</b><br>(mg/m <sup>3</sup> @ 11% O <sub>2</sub> ) |
|--------------|--|--|--|---|
| Pb           | 0.00469  | 0.00518  | 0.00496  | 0.00494   |
| Sb           | 0.00131  | 0.00104  | 0.00036  | 0.00090   |
| Cu           | 0.00176  | 0.00109  | 0.00131  | 0.00138   |
| Mn           | 0.00093  | 0.00086  | 0.00093  | 0.00091   |
| V            | 0.00031  | 0.00032  | 0.00029  | 0.00031   |
| Zn           | 0.02397  | 0.02952  | 0.03174  | 0.02841   |
| As           | 0.00056  | 0.00032  | 0.00029  | 0.00039   |
| Cr           | 0.00052  | 0.00328  | 0.00252  | 0.00210   |
| Co           | 0.00008  | 0.00008  | 0.00015  | 0.00010   |
| Ni           | 0.00145  | 0.00456  | 0.00113  | 0.00238   |
| Se           | 0.00046  | 0.00181  | 0.00044  | 0.00090   |
| Te           | 0.00062  | 0.00202  | 0.00177  | 0.00147   |
| Tl           | 0.00046  | 0.00126  | 0.00155  | 0.00109   |
| Cd           | 0.00025  | 0.00026  | 0.00033  | 0.00028   |
| Hg           | 0.00004  | 0.00005  | 0.00007  | 0.00005   |

All data is corrected to standard conditions (S) of 20 °C, 101.325 kPa (dry) unless otherwise noted.

**Table 6: Unit 1 - Summary of Operating Data**

| Parameter                             |                    | Run 1         | Run 2         | Run 3         | Normal |
|---------------------------------------|--------------------|---------------|---------------|---------------|--------|
| Unit - 1                              |                    |               |               |               |        |
| Test Date - Particulate/Metals        |                    | 12-Feb-24     | 13-Feb-24     | 13-Feb-24     |        |
| Test Time - Particulate/Metals        |                    | 12:19 - 14:20 | 09:16 - 11:18 | 11:45 - 13:47 |        |
|                                       |                    |               |               |               |        |
| Boiler Steam Production               | (kg/hr)            | 37247         | 37693         | 37262         | 29581  |
| Percentage of normal                  | (%)                | 126%          | 127%          | 126%          |        |
|                                       |                    |               |               |               |        |
| Boiler Secondary Combustion Zone Temp | (°C)               | 1005          | 930           | 914           | 841    |
| Percentage of normal                  | (%)                | 120%          | 111%          | 109%          |        |
|                                       |                    |               |               |               |        |
| Rate of refuse fired                  | (kg/hr)            | 10642         | 10769         | 10646         | 8452   |
| Percentage of normal                  | (%)                | 126%          | 127%          | 126%          |        |
|                                       |                    |               |               |               |        |
| Rate of aux. fuel fired (Natural Gas) | m <sup>3</sup> /hr | 0             | 0             | 0             | 66     |
| Percentage of normal (%)              | (%)                | 0%            | 0%            | 0%            |        |
|                                       |                    |               |               |               |        |

\*Normal refers to the average operating rate from the previous 30 days

**Table 7: Unit 2 Summary of Emission Test Results**

| <b>Parameter</b>   | <b>Run 1</b>  | <b>Run 2</b>  | <b>Run 3</b>  | <b>Average</b> |
|--|---------------|---------------|---------------|----------------|
| Test Date - Particulate/Metals   | 13-Feb-24     | 14-Feb-24     | 14-Feb-24     |                |
| Test Time - Particulate/Metals   | 11:29 - 13:31 | 08:38 - 10:46 | 10:56 - 13:18 |                |
| Duration - Minutes   | 120           | 120           | 120           |                |
| Test Date - Acid Gases   | 14-Feb-24     | 14-Feb-24     | 14-Feb-24     |                |
| Test Time - Acid Gases   | 09:09-10:09   | 10:27-11:27   | 13:20-14:20   |                |
| Duration - Minutes   | 60            | 60            | 60            |                |
| Stack Temperature (°C)   | 154           | 151           | 153           | 153            |
| Average Gas Velocity (m/s)   | 12.9          | 13.2          | 13.2          | 13.1           |
| Dry Flow Rate (Sm <sup>3</sup> /min)   | 1111          | 1140          | 1189          | 1147           |
| Moisture (Vol. %)  | 14.4          | 14.0          | 14.6          | 14.3           |
| Oxygen (Vol. %)(dry basis)   | 10.3          | 10.6          | 10.1          | 10.3           |
| Carbon Dioxide (Vol. %)(dry basis)   | 10.1          | 9.83          | 10.0          | 10.0           |
| <b>Particulate (mg/Sm<sup>3</sup> @ 11% O<sub>2</sub>)</b>                                 | 0.50          | 0.45          | 0.82          | <b>0.59</b>    |
| <b>Hydrogen Fluoride (mg/Sm<sup>3</sup> @ 11% O<sub>2</sub>)</b>                           | 0.049         | 0.057         | 0.010         | <b>0.039</b>   |
| <b>Ammonia (mg/Sm<sup>3</sup> @ 11% O<sub>2</sub>)</b>                                     | 1.54          | 2.86          | 1.69          | <b>2.03</b>    |
| <b>Nitrous Oxide (mg/Sm<sup>3</sup> @ 11% O<sub>2</sub>)*</b>                              | 1.03          | 5.48          | 2.51          | <b>3.01</b>    |
| <b>Total Hydrocarbons (mg/Sm<sup>3</sup> @ 11% O<sub>2</sub>)</b>                          | 2.54          | 2.24          | 2.37          | <b>2.38</b>    |
| <b>Trace Metals - Operational Certificate List (mg/Sm<sup>3</sup> @ 11% O<sub>2</sub>)</b> |               |               |               |                |
| <b>OC Class (Pb, As and Cr)</b>  | 0.00297       | 0.01351       | 0.00417       | <b>0.00689</b> |
| <b>Aluminum (mg/Sm<sup>3</sup> @ 11% O<sub>2</sub>)</b>                                    | 0.01043       | 0.01328       | 0.00974       | 0.01115        |
| <b>Cadmium (mg/Sm<sup>3</sup> @ 11% O<sub>2</sub>)</b>                                     | 0.00009       | 0.00010       | 0.00009       | 0.00009        |
| <b>Lead (mg/Sm<sup>3</sup> @ 11% O<sub>2</sub>)</b>  | 0.00056       | 0.00184       | 0.00078       | 0.00106        |
| <b>Mercury (mg/Sm<sup>3</sup> @ 11% O<sub>2</sub>)</b>                                     | 0.00007       | 0.00005       | 0.00006       | 0.00006        |
| <b>Phosphorus (mg/Sm<sup>3</sup> @ 11% O<sub>2</sub>)</b>                                  | 0.00093       | 0.00098       | 0.00087       | 0.00093        |
| Isokinetic Variation ( % )   | 101           | 101           | 98.5          | 100            |

\*N<sub>2</sub>O was sampled on February 14, 2024

All data is corrected to standard conditions (S) of 20 °C, 101.325 kPa (dry) unless otherwise noted.



**Table 8: Unit 2 Trace Metals Emissions (OC Class)**

| <b>Metal</b>    | <b>Test 1</b><br>(mg/m <sup>3</sup> @ 11% O <sub>2</sub> ) | <b>Test 2</b><br>(mg/m <sup>3</sup> @ 11% O <sub>2</sub> ) | <b>Test 3</b><br>(mg/m <sup>3</sup> @ 11% O <sub>2</sub> ) | <b>Average</b><br>(mg/m <sup>3</sup> @ 11% O <sub>2</sub> ) |
|-----------------|--|--|--|---|
| <b>OC Class</b> |  |  |  |   |
| Pb              | 0.00056  | 0.00184  | 0.00078  | 0.00106   |
| As              | 0.00037  | 0.00039  | 0.00118  | 0.00065   |
| Cr              | 0.00204  | 0.01129  | 0.00221  | 0.00518   |
| Sum of OC Class | 0.00297  | 0.01351  | 0.00417  | 0.00689   |
| <b>Other</b>    |  |  |  |   |
| Al              | 0.01043  | 0.01328  | 0.00974  | 0.01115   |
| Cd              | 0.00009  | 0.00010  | 0.00009  | 0.00009   |
| P               | 0.00093  | 0.00098  | 0.00087  | 0.00093   |
| Hg              | 0.00007  | 0.00005  | 0.00006  | 0.00006   |

All data is corrected to standard conditions (S) of 20 °C, 101.325 kPa (dry) unless otherwise noted.

**Table 9: Unit 2 Detailed Trace Metals Emissions**

| <b>Metal</b> | <b>Test 1</b><br>(mg/m <sup>3</sup> @ 11% O <sub>2</sub> ) | <b>Test 2</b><br>(mg/m <sup>3</sup> @ 11% O <sub>2</sub> ) | <b>Test 3</b><br>(mg/m <sup>3</sup> @ 11% O <sub>2</sub> ) | <b>Average</b><br>(mg/m <sup>3</sup> @ 11% O <sub>2</sub> ) |
|--------------|--|--|--|---|
| Pb           | 0.00056  | 0.00184  | 0.00078  | 0.00106   |
| Sb           | 0.00093  | 0.00098  | 0.00087  | 0.00093   |
| Cu           | 0.00020  | 0.00125  | 0.00035  | 0.00060   |
| Mn           | 0.00074  | 0.00172  | 0.00070  | 0.00105   |
| V            | 0.00037  | 0.00039  | 0.00035  | 0.00037   |
| Zn           | 0.00719  | 0.01191  | 0.00762  | 0.00891   |
| As           | 0.00037  | 0.00039  | 0.00118  | 0.00065   |
| Cr           | 0.00204  | 0.01129  | 0.00221  | 0.00518   |
| Co           | 0.00009  | 0.00024  | 0.00009  | 0.00014   |
| Ni           | 0.00134  | 0.01132  | 0.00136  | 0.00467   |
| Se           | 0.00056  | 0.00059  | 0.00052  | 0.00056   |
| Te           | 0.00078  | 0.00144  | 0.00070  | 0.00097   |
| Tl           | 0.00056  | 0.00059  | 0.00052  | 0.00056   |
| Cd           | 0.00009  | 0.00010  | 0.00009  | 0.00009   |
| Hg           | 0.00007  | 0.00005  | 0.00006  | 0.00006   |

All data is corrected to standard conditions (S) of 20 °C, 101.325 kPa (dry) unless otherwise noted.

**Table 10: Unit 2 - Summary of Operating Data**

| Parameter                                    |                         | Run 1         | Run 2         | Run 3         | Normal |
|--|-------------------------|---------------|---------------|---------------|--------|
| <b>Unit - 2</b>                              |                         |               |               |               |        |
| <b>Test Date - Particulate/Metals</b>        |                         | 13-Feb-24     | 14-Feb-24     | 14-Feb-24     |        |
| <b>Test Time - Particulate/Metals</b>        |                         | 11:29 - 13:31 | 08:38 - 10:46 | 10:56 - 13:18 |        |
|  |                         |               |               |               |        |
| <b>Boiler Steam Production</b>               | <b>(kg/hr)</b>          | 40277         | 39071         | 39552         | 33854  |
| <b>Percentage of normal</b>                  | <b>(%)</b>              | 119%          | 115%          | 117%          |        |
|  |                         |               |               |               |        |
| <b>Boiler Secondary Combustion Zone Temp</b> | <b>(°C)</b>             | 952           | 916           | 923           | 868    |
| <b>Percentage of normal</b>                  | <b>(%)</b>              | 110%          | 106%          | 106%          |        |
|  |                         |               |               |               |        |
| <b>Rate of refuse fired</b>                  | <b>(kg/hr)</b>          | 11508         | 11163         | 11301         | 9673   |
| <b>Percentage of normal</b>                  | <b>(%)</b>              | 119%          | 115%          | 117%          |        |
|  |                         |               |               |               |        |
| <b>Rate of aux. fuel fired (Natural Gas)</b> | <b>m<sup>3</sup>/hr</b> | 0             | 0             | 0             | 110    |
| <b>Percentage of normal (%)</b>              | <b>(%)</b>              | 0%            | 0%            | 0%            |        |
|  |                         |               |               |               |        |

\*Normal refers to the average operating rate from the previous 30 days

**Table 11: Unit 3 Summary of Emission Test Results**

| <b>Parameter</b>   | <b>Run 1</b>  | <b>Run 2</b>  | <b>Run 3</b> | <b>Average</b> |
|--|---------------|---------------|--------------|----------------|
| Test Date - Particulate/Metals   | 14-Feb-24     | 15-Feb-24     | 15-Feb-24    |                |
| Test Time - Particulate/Metals   | 13:39 - 15:44 | 08:41 - 10:42 | 10:46-12:47  |                |
| Duration - Minutes   | 120           | 120           | 120          |                |
| Test Date - Acid Gases   | 15-Feb-24     | 15-Feb-24     | 15-Feb-24    |                |
| Test Time - Acid Gases   | 09:03-10:03   | 10:16-11:16   | 11:29-12:29  |                |
| Duration - Minutes   | 60            | 60            | 60           |                |
| Stack Temperature (°C)   | 156           | 157           | 157          | 156            |
| Average Gas Velocity (m/s)   | 13.2          | 13.1          | 13.4         | 13.2           |
| Dry Flow Rate (Sm <sup>3</sup> /min)   | 1105          | 1125          | 1121         | 1117           |
| Moisture (Vol. %)  | 15.9          | 13.6          | 15.6         | 15.0           |
| Oxygen (Vol. %)(dry basis)   | 9.10          | 10.2          | 10.3         | 9.88           |
| Carbon Dioxide (Vol. %)(dry basis)   | 10.9          | 10.0          | 10.0         | 10.3           |
| <b>Particulate</b> (mg/Sm <sup>3</sup> @ 11% O <sub>2</sub> )                              | 1.20          | 2.42          | 1.53         | <b>1.72</b>    |
| <b>Hydrogen Fluoride</b> (mg/Sm <sup>3</sup> @ 11% O <sub>2</sub> )                        | 0.007         | 0.008         | 0.047        | <b>0.020</b>   |
| <b>Ammonia</b> (mg/Sm <sup>3</sup> @ 11% O <sub>2</sub> )                                  | 4.29          | 5.61          | 2.65         | <b>4.18</b>    |
| <b>Nitrous Oxide</b> (mg/Sm <sup>3</sup> @ 11% O <sub>2</sub> )*                           | 0.61          | 0.76          | 0.86         | <b>0.74</b>    |
| <b>Total Hydrocarbons</b> (mg/Sm <sup>3</sup> @ 11% O <sub>2</sub> )                       | 3.34          | 2.76          | 3.93         | <b>3.34</b>    |
| <b>Trace Metals - Operational Certificate List (mg/Sm<sup>3</sup> @ 11% O<sub>2</sub>)</b> |               |               |              |                |
| <b>OC Class</b> (Pb, As and Cr)  | 0.00471       | 0.00652       | 0.00355      | <b>0.00493</b> |
| <b>Aluminum</b> (mg/Sm <sup>3</sup> @ 11% O <sub>2</sub> )                                 | 0.01638       | 0.00844       | 0.00536      | 0.01006        |
| <b>Cadmium</b> (mg/Sm <sup>3</sup> @ 11% O <sub>2</sub> )                                  | 0.00020       | 0.00009       | 0.00010      | 0.00013        |
| <b>Lead</b> (mg/Sm <sup>3</sup> @ 11% O <sub>2</sub> )                                     | 0.00215       | 0.00329       | 0.00155      | 0.00233        |
| <b>Mercury</b> (mg/Sm <sup>3</sup> @ 11% O <sub>2</sub> )                                  | 0.00003       | 0.00004       | 0.00005      | 0.00004        |
| <b>Phosphorus</b> (mg/Sm <sup>3</sup> @ 11% O <sub>2</sub> )                               | 0.00026       | 0.00220       | 0.00191      | 0.00146        |
| Isokinetic Variation ( % )   | 103           | 101           | 101          | 102            |

\*N<sub>2</sub>O was sampled on February 15, 2024

All data is corrected to standard conditions (S) of 20 °C, 101.325 kPa (dry) unless otherwise noted.

**Table 12: Unit 3 Trace Metals Emissions (OC Class)**

| <b>Metal</b>    | <b>Test 1</b><br>(mg/m <sup>3</sup> @ 11% O <sub>2</sub> ) | <b>Test 2</b><br>(mg/m <sup>3</sup> @ 11% O <sub>2</sub> ) | <b>Test 3</b><br>(mg/m <sup>3</sup> @ 11% O <sub>2</sub> ) | <b>Average</b><br>(mg/m <sup>3</sup> @ 11% O <sub>2</sub> ) |
|-----------------|--|--|--|---|
| <b>OC Class</b> |  |  |  |   |
| Pb              | 0.00215  | 0.00329  | 0.00155  | 0.00233   |
| As              | 0.00026  | 0.00037  | 0.00038  | 0.00034   |
| Cr              | 0.00230  | 0.00287  | 0.00162  | 0.00226   |
| Sum of OC Class | 0.00471  | 0.00652  | 0.00355  | 0.00493   |
| <b>Other</b>    |  |  |  |   |
| Al              | 0.01638  | 0.00844  | 0.00536  | 0.01006   |
| Cd              | 0.00020  | 0.00009  | 0.00010  | 0.00013   |
| P               | 0.00026  | 0.00220  | 0.00191  | 0.00146   |
| Hg              | 0.00003  | 0.00004  | 0.00005  | 0.00004   |

All data is corrected to standard conditions (S) of 20 °C, 101.325 kPa (dry) unless otherwise noted.

**Table 13: Unit 3 Detailed Trace Metals Emissions**

| <b>Metal</b> | <b>Test 1</b><br>(mg/m <sup>3</sup> @ 11% O <sub>2</sub> ) | <b>Test 2</b><br>(mg/m <sup>3</sup> @ 11% O <sub>2</sub> ) | <b>Test 3</b><br>(mg/m <sup>3</sup> @ 11% O <sub>2</sub> ) | <b>Average</b><br>(mg/m <sup>3</sup> @ 11% O <sub>2</sub> ) |
|--------------|--|--|--|---|
| Pb           | 0.00215  | 0.00329  | 0.00155  | 0.00233   |
| Sb           | 0.00064  | 0.00092  | 0.00201  | 0.00119   |
| Cu           | 0.00054  | 0.00041  | 0.00043  | 0.00046   |
| Mn           | 0.00064  | 0.00078  | 0.00043  | 0.00062   |
| V            | 0.00026  | 0.00037  | 0.00038  | 0.00034   |
| Zn           | 0.01336  | 0.01597  | 0.01578  | 0.01504   |
| As           | 0.00026  | 0.00037  | 0.00038  | 0.00034   |
| Cr           | 0.00230  | 0.00287  | 0.00162  | 0.00226   |
| Co           | 0.00006  | 0.00009  | 0.00010  | 0.00008   |
| Ni           | 0.00410  | 0.00450  | 0.00140  | 0.00333   |
| Se           | 0.00038  | 0.00055  | 0.00057  | 0.00050   |
| Te           | 0.00077  | 0.00147  | 0.00077  | 0.00100   |
| Tl           | 0.00038  | 0.00055  | 0.00057  | 0.00050   |
| Cd           | 0.00020  | 0.00009  | 0.00010  | 0.00013   |
| Hg           | 0.00003  | 0.00004  | 0.00005  | 0.00004   |

All data is corrected to standard conditions (S) of 20 °C, 101.325 kPa (dry) unless otherwise noted.

**Table 14: Unit 3 - Summary of Operating Data**

| Parameter                                    |                         | Run 1         | Run 2         | Run 3       | Normal |
|--|-------------------------|---------------|---------------|-------------|--------|
| <b>Unit - 3</b>                              |                         |               |               |             |        |
| <b>Test Date - Particulate/Metals</b>        |                         | 14-Feb-24     | 15-Feb-24     | 15-Feb-24   |        |
| <b>Test Time - Particulate/Metals</b>        |                         | 13:39 - 15:44 | 08:41 - 10:42 | 10:46-12:47 |        |
|  |                         |               |               |             |        |
| <b>Boiler Steam Production</b>               | <b>(kg/hr)</b>          | 39197         | 39070         | 39141       | 33189  |
| <b>Percentage of normal</b>                  | <b>(%)</b>              | 118%          | 118%          | 118%        |        |
|  |                         |               |               |             |        |
| <b>Boiler Secondary Combustion Zone Temp</b> | <b>(°C)</b>             | 897           | 900           | 905         | 856    |
| <b>Percentage of normal</b>                  | <b>(%)</b>              | 105%          | 105%          | 106%        |        |
|  |                         |               |               |             |        |
| <b>Rate of refuse fired</b>                  | <b>(kg/hr)</b>          | 11199         | 11163         | 11183       | 9483   |
| <b>Percentage of normal</b>                  | <b>(%)</b>              | 118%          | 118%          | 118%        |        |
|  |                         |               |               |             |        |
| <b>Rate of aux. fuel fired (Natural Gas)</b> | <b>m<sup>3</sup>/hr</b> | 0             | 0             | 0           | 87     |
| <b>Percentage of normal (%)</b>              | <b>(%)</b>              | 0%            | 0%            | 0%          |        |
|  |                         |               |               |             |        |

\*Normal refers to the average operating rate from the previous 30 days

---

## DISCUSSION

All Units are in compliance with limits as set out in the OC.

The Run 2 sample for N<sub>2</sub>O on Unit 3 was destroyed in transportation. Therefore, the average of Runs 1 and 3 was entered to represent a third replicate.

As stated in Section 2.1, EPA Method 5/29 was modified slightly to accommodate performance based analytical protocols utilized in B.C. for trace metals sampling and analysis. The analytical modification consists of using volumes of recovery reagents different than the method stipulates. In order to validate (ie performance-based QA) the modification, sample Blanks and all samples were made up to the same volume, so that subtraction of the Blank data, was done on equivalent sample sizes. In addition, special Hg spiking of blank filters and peroxide solutions was conducted. This spiking is referred to as a “matrix spike” and is reported in Appendix B, Quality Control for mercury, where the recovery of spiked mercury was calculated to be an acceptable 85 to 115%. It should be noted that independent front half/back half analysis of all trace metals was conducted for this survey. In addition, individual quartz filter blanks were analyzed for each unit.

Sampling was conducted in accordance with their respective reference methods (EPA 29 except as discussed) and passed all appropriate quality assurance and quality control criteria. None of the sample points on any of the three units were outside of the allowable +/- 10% for isokinetic rate.

During the monitoring, there were no environmental observations made that would impact the validity of the test program. The weather was normal with light rain and wind on one day, but otherwise dry.

All sampling was conducted/supervised by certified emission testing personnel, using calibrated source sampling equipment and quality-controlled reagents. It is therefore

---

stated that the survey and this report complies with MV's WTEF compliance testing requirements for this first survey in 2024.