



**A. Lanfranco
& Associates Inc.**

Environmental Consultants

Prepared for

METRO VANCOUVER

Metrotower III

**4515 Central Boulevard
Burnaby, BC V5H 0C6**

Waste-to-Energy Facility
Fourth Quarter 2025 Emissions Test Report
Operational Certificate 107051
Prepared by Mr. Louis Agassiz
Issued: December 19, 2025

CERTIFICATION

The field monitoring for this survey was conducted by certified stack test technicians as required by the British Columbia Ministry of Environment and Parks (BC MOE) Field Sampling Manual.

The field crew consisted of:

Mr. C. Lanfranco (certified), Mr. D. Sampson (certified), Mr. J. Gibbs (certified), Mr. L. Forrer (certified), Mr. C. De La O (certified), and Mr. J. Dennis.

The report was prepared by Mr. L. Agassiz using reporting principles and guidelines generally acceptable to Metro Vancouver (MV).

The field crew and A. Lanfranco and Associates Inc. certify that the test methods used were BC MOE/MV approved reference methods for the parameters investigated.

Report reviewed on December 19, 2025, by:



Mr. Mark Lanfranco
Principal | Owner

Table of Contents

SUMMARY	3
1 TEST PROGRAM ORGANIZATION and INTRODUCTION	4
2 METHODOLOGY	6
2.1 Sampling and Analytical Methods	6
3 DETAILED TEST RESULTS	13
4 DISCUSSION	22

List of Tables

Table 1: Summary Comparison of Emissions Test Results with Limits	3
Table 2: Reference Methods	6
Table 3: Unit 1 Summary of Emission Test Results.....	13
Table 4: Unit 1 Trace Metals Emissions (OC Class).....	14
Table 5: Unit 1 Detailed Trace Metals Emissions	14
Table 6: Unit 1 - Summary of Operating Data	15
Table 7: Unit 2 Summary of Emission Test Results.....	16
Table 8: Unit 2 Trace Metals Emissions (OC Class).....	17
Table 9: Unit 2 Detailed Trace Metals Emissions	17
Table 10: Unit 2 - Summary of Operating Data	18
Table 11: Unit 3 Summary of Emission Test Results.....	19
Table 12: Unit 3 Trace Metals Emissions (OC Class).....	20
Table 13: Unit 3 Detailed Trace Metals Emissions	20
Table 14: Unit 3 - Summary of Operating Data	21

List of Figures

Figure 1: Example showing circular stack cross section divided	7
Figure 2: Type S Pitot Tube Manometer Assembly	7
Figure 3: Particulate / Trace Metals Sampling Train.....	9
Figure 4: Hexavalent Chromium Sampling Train	11

SUMMARY

The following table displays the emission results from the three units located at Metro Vancouver's Waste-To-Energy Facility (WTEF) as well as the current emission limits as defined by the Operational Certificate (OC) issued by BC Ministry of Environment and Parks. This compliance survey represents the fourth quarter of 2025.

Table 1: Summary Comparison of Emissions Test Results with Limits

Parameter	Limit	Unit 1	Unit 2	Unit 3	Facility Average
Test Date		Nov 17-18, 2025	Nov 18-19, 2025	Nov 19-20, 2025	
Particulate (mg/Sm ³ @ 11% O ₂)	9.0	0.66	0.44	0.44	0.52
Hydrogen Fluoride (mg/Sm ³ @ 11% O ₂)	1.0	0.101	0.106	0.100	0.102
Hexavalent Chromium (mg/Sm ³ @ 11% O ₂)	-	0.00021	-	-	0.00021
Trace Metals - OC Class (mg/Sm ³ @ 11% O ₂)					
Lead (Pb)	-	0.0007	0.0005	0.0010	0.0008
Arsenic (As)	-	0.0007	0.0004	0.0003	0.0005
Chromium (Cr)	-	0.0004	0.0017	0.0012	0.0011
OC Class Sum (Pb, As and Cr)	0.064	0.0018	0.0027	0.0025	0.0023
Mercury (mg/Sm ³ @ 11% O ₂)	0.02	0.000068	0.000068	0.000047	0.00006
Cadmium (mg/Sm ³ @ 11% O ₂)	0.007	0.000140	0.000129	0.000123	0.00013

All data is corrected to standard conditions (S) of 20 °C, 101.325 kPa (dry) unless otherwise noted.

The test results are very similar to those from Q3 2025. The variability observed quarter-to-quarter is well within a normal range of outcomes for this operation and is not considered significant.

Hexavalent Chromium was measured on Unit 1 this survey and detailed results are reported in Table 1. These results are like historical data and at the analytical reporting limit.

1 TEST PROGRAM ORGANIZATION and INTRODUCTION

Primary Stakeholders:	Mr. Brent Kirkpatrick Metro Vancouver Lead Senior Engineer Email: brent.kirkpatrick@metrovancover.org Tel: (604) 451-6623
	Mr. Brian Graham Veolia Canada Operations Manager / Chief Power Engineer Email: brian.graham@veolia.com Tel: (587) 892-1381
Project Manager:	Mr. Mark Lanfranco President Owner A. Lanfranco and Associates Inc. 101 – 9488 189 St Surrey, BC Canada V4N 4W7 Tel: (604) 881-2582 Email: mark.lanfranco@alanfranco.com
Sampling Crew:	Mr. C. Lanfranco - A. Lanfranco and Associates Inc. Mr. D. Sampson - A. Lanfranco and Associates Inc. Mr. J. Gibbs - A. Lanfranco and Associates Inc. Mr. L. Forrer - A. Lanfranco and Associates Inc. Mr. C. De La O - A. Lanfranco and Associates Inc. Mr. J. Dennis - A. Lanfranco and Associates Inc.

Metro Vancouver (MV) commissioned an emission survey at the Waste-To-Energy Facility (WTEF) in Burnaby BC, as required by the provincially approved Operational Certificate (OC). Stationary source monitoring is required Quarterly.

The individual sources that were monitored for compliance are identified as Unit 1, Unit 2 and Unit 3 which represent the three distinct processing lines at the WTEF. The three boilers are identified as discharge E300670 in the operational certificate.

The survey included monitoring for: filterable particulate matter, trace metals, mercury (Hg), hydrogen fluoride (HF), hydrogen chloride (HCl), ammonia (NH₃), nitrous oxide (N₂O) and volatile organic compounds (VOC). In addition to the typical quarterly scope, hexavalent chromium was also measured on Unit 1.

A. Lanfranco and Associates Inc. (ALAA), of Surrey, B.C., conducted the sampling program on behalf of MV. The sampling program consisted of, but was not limited to, the planning, execution, analysis, and reporting of three emission sources located at the WTEF.

This report includes a comparison of emission results to limits established in the OC, detailed emission results, a brief outline of methods employed, equipment used, and a discussion of the survey. All supporting data and appendices are presented under separate cover.

The appendices for this report, including computer outputs of calculated data, analytical data, field data sheets, calibrations, and professional certifications are issued separately.

2 METHODOLOGY

All services provided by A. Lanfranco and Associates Inc. were conducted in accordance with approved reference methods as issued by:

- Metro Vancouver (MV)
- BC Ministry of Environment & Parks (BC MOE)
- Environment Canada (EC)
- US Environmental Protection Agency (EPA)

2.1 Sampling and Analytical Methods

The following table lists the test methods used for the different parameters measured. The subsequent paragraphs briefly describe each method.

Table 2: Reference Methods

<u>Parameter</u>	<u>Reference Method</u>
Sample and Velocity traverse points	EPS 1/RM/8 A Determination of Sampling Site and Traverse Points
Velocity and flowrate	EPS 1/RM/8 B Determination of Stack Gas Velocity and Volumetric Flow Rate (Type S Pitot Tube)
Gas molecular weight (O ₂ /CO ₂)	EPS 1/RM/8 C Determination of Molecular Weight by Gas Analysis
Flue gas Moisture	EPS 1/RM/8 D Determination of Moisture Content
Particulate Matter	EPS 1/RM/8 E Determination of Particulate Matter Emissions from Stationary Sources
Trace Metals with Mercury	EPA Method 29 Determination of Metals Emissions from Stationary Sources
Hydrogen Fluoride (HF), Hydrogen Chloride (HCl), Ammonia (NH ₃)	EPA Method 26 Determination of Hydrogen Halide and Halogen Emissions from Stationary Sources Non-Isokinetic method
Nitrous Oxide (N ₂ O)	N/A
Volatile Organic Compounds (VOC)	EPA Method TO-15 Determination of Volatile Organic Compounds in Air
Hexavalent Chromium (Cr ⁶⁺)	EPA Method 0061

Sampling Site and Traverse Points

Primary: EPS 1/RM/8 Method A

Supporting: EPA Method 1

This method is designed to aid in the representative measurement of pollutant emissions and/or total volumetric flow rate from a stationary source. A measurement site where the effluent stream is flowing in a known direction is selected, and the cross-section of the stack is divided into a number of equal areas. Traverse points are then located within each of these equal areas.

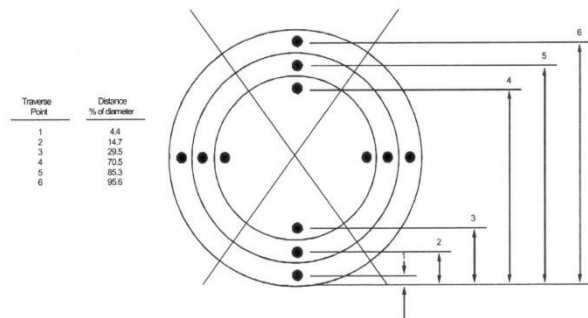

Figure 1: Example showing circular stack cross section divided

Stack Gas Velocity and Volumetric Flow Rate

Primary: EPS 1/RM/8 Method B

Supporting: EPA Method 2

The average gas velocity in a stack or duct is determined from the gas density and from the measurement of velocity pressure with an S-type pitot tube. A standard pitot tube may be used where plugging of the tube openings due to particulate matter and/or moisture is not likely to occur. Stack gas volumetric flow rate is determined from measurements of stack gas velocity, temperature, absolute pressure, dry gas composition, moisture content, and stack diameter.

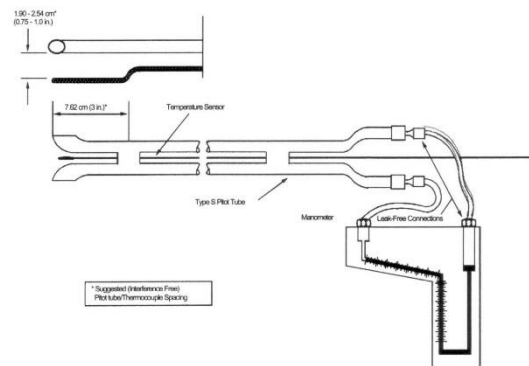

Figure 2: Type S Pitot Tube Manometer Assembly

Molecular Weight by Gas Analysis

Primary: EPS 1/RM/8 Method C
Supporting: EPA Method 3

An integrated or grab sample is extracted from a single point in the gas stream and analyzed for its components using a Fyrite analyzer, a gas chromatograph, or calibrated continuous analyzers.

Moisture Content

Primary: EPS 1/RM/8 Method D
Supporting: EPA Method 4

A gas sample is extracted from a single point in the enclosed gas stream being sampled. The moisture is condensed, and its weight measured. This weight, together with the volume of gas sampled, enables the stack gas moisture content to be calculated.

Particulate Matter

Primary: EPS 1/RM/8 Method E
Supporting: EPA Method 5

Particulate matter is withdrawn isokinetically from a number of sampling or traverse points in an enclosed gas stream. The particulate sample is collected in the nozzle, probe, and on a glass fibre filter, all maintained at a temperature of $120 \pm 14^{\circ}\text{C}$ or such other temperature as is necessary to prevent blinding of the filter from condensation. The particulate weight is determined gravimetrically after removal of uncombined water. Simultaneous determinations of the gas stream moisture content, velocity, temperature, and molecular weight allow calculations of the particulate concentration and the particulate mass emission or release rate to be made.

Trace Metal

Primary: EPA Method 29 (modified)

This method is used in conjunction with the above Method 5. A stack sample is withdrawn isokinetically from the source. Particulate emissions are collected in the probe and on a heated filter, and gaseous emissions are then collected in an aqueous acidic solution of hydrogen peroxide (analyzed for all metals including Hg) and an aqueous acidic solution of potassium permanganate (analyzed only for Hg). The recovered samples are digested, and appropriate fractions are analyzed for Hg by cold vapour atomic absorption spectroscopy (CVAAS). The remaining trace metals are analyzed with inductively coupled argon plasma emission spectroscopy (ICAP), atomic absorption spectroscopy (AAS) and graphite furnace atomic absorption spectroscopy (GFAAS). Figure 3 presents the sample train and its configuration.

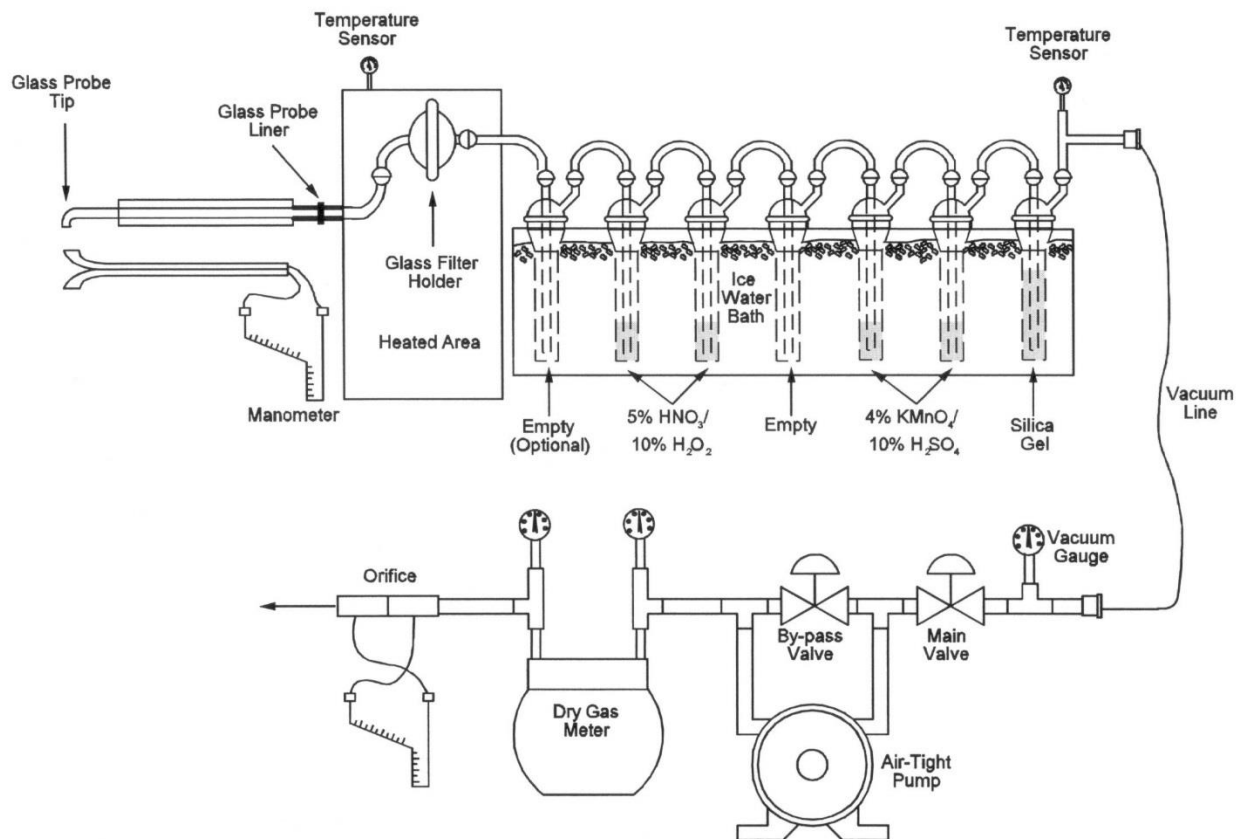

Figure 3: Particulate / Trace Metals Sampling Train

Hydrogen Fluoride Primary: US EPA Method 26

HF is sampled in a four-impinger train consisting of two impingers containing 0.1 N H₂SO₄, one empty impinger, and a fourth containing silica gel. A sample of the stack gas is extracted from a single point near the centre of the stack over the sample duration at a constant rate. The collected samples are measured for F by ion chromatography at Element laboratory in Surrey, BC.

Hydrogen Chloride Primary: US EPA Method 26

A sample of the stack gas is extracted from a single point near the centre of the stack over a sampling duration of 60 minutes. After the removal of particulate matter from the sample gas, hydrogen chloride is collected by impingement in a series of impingers containing measured amounts of 0.1N H₂SO₄. The resulting solutions are analyzed for chlorides by ion chromatography at Element laboratory in Surrey, BC.

Ammonia Primary: US EPA Method 26

The absorbing solution in the first two impingers is 0.1 N H₂SO₄ and the triplicate samples were extracted at a constant rate for 60-minute durations. The collected samples are analyzed at Element laboratory in Surrey, BC.

N₂O Primary: US EPA Method 18

Three N₂O samples were collected from each source using evacuated tedlar bag sampling procedures. Each bag was purged and evacuated on-site with small amounts of stack gas, prior to final stack gas collection. Each bag sample was an integrated type sample where stack gases were collected over sixty-minute periods. The bag sampling was conducted over about a four-hour period.

The samples were analyzed at Bureau Veritas in Mississauga, ON by SOP-00203 utilizing GC/ECD.

The Method 0061 sampling train (see Fig. 4) was used to collect samples, where all train components were Teflon or borosilicate glass. A small amount of 0.1 N KOH is re-circulated through the probe and first impinger via peristaltic pump. The impinger components were:

Stack Impingers

- 150 ml 0.1 N KOH
- 75 ml 0.1 N KOH
- 75 ml 0.1 N KOH
- Empty
- 200 silica gel

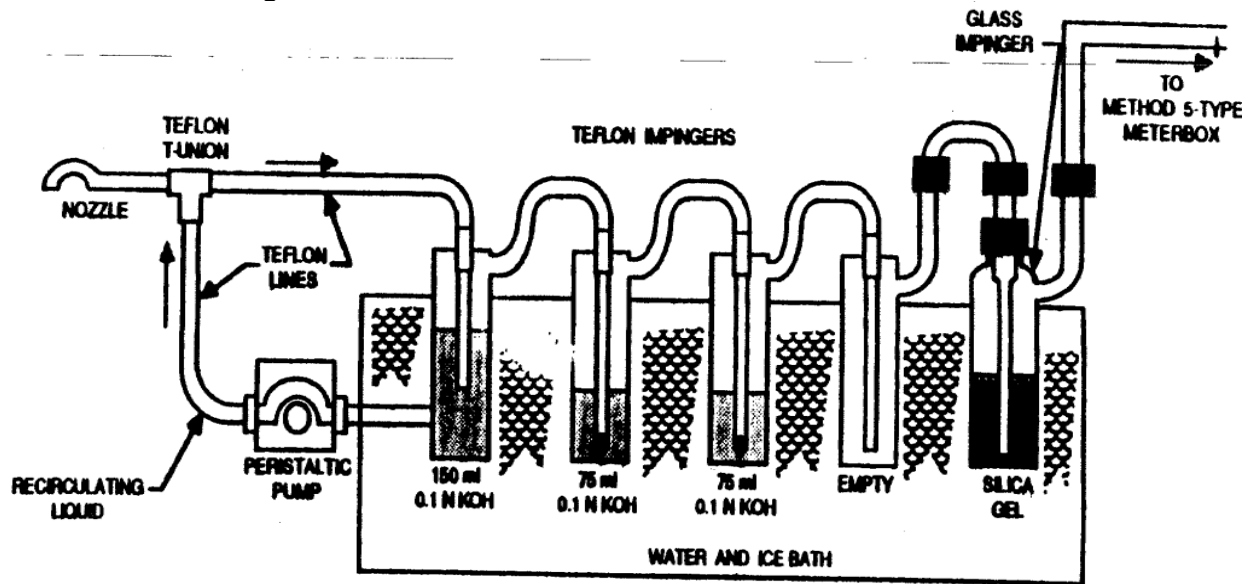

Figure 4: Hexavalent Chromium Sampling Train

Method Modifications

Three minor method modifications were instituted for this work.

1. Reagent blanks for metals trains were made to the same volumes as all samples. In other words, exactly 100 ml of the various reagents used to recover samples was NOT done, as some sample components (probe washing for example) required more than 100 ml to adequately clean and rinse the probe. Instead, sample recovery was conducted with however much rinsing was deemed adequate. In the laboratory, the blanks and samples were made up with the appropriate reagent so that all samples and blanks were the same volume.
2. Filter and residue weighing were not conducted with the six-hour interval technique. Instead, the sample filters and beakers were conditioned with cooling and desiccation and then weighed on two separate laboratory scales after 24 hours. Duplicate or triplicate Blank samples were carried through the gravimetric analysis, and the sample results were adjusted with the Blank data to determine the net filter and probe wash residue weight gain. This is the Environment Canada approved modified approach for weighing probe wash residue.
3. For the purposes of calculating a result, all parameters were given the value of $\frac{1}{2}$ the detection limit when the analysis yielded 'non-detect' results.

All results are expressed using the metric system and corrected to standard conditions of 20 °C and 101.325 kPa, dry gas (unless otherwise noted).

3 DETAILED TEST RESULTS

The results of stack emissions were calculated using a “STACK” computer program developed by A. Lanfranco and Associates for BC MOE requirements. Tables 3-14 present the detailed results of all emissions parameters tested and operational conditions for each of the units. Additional data and the computer outputs can be found in the accompanying Appendices.

Table 3: Unit 1 Summary of Emission Test Results

Parameter	Run 1	Run 2	Run 3	Average
Test Date - Particulate/Metals	17-Nov-25	18-Nov-25	18-Nov-25	
Test Time - Particulate/Metals	12:27 - 14:29	08:53 - 10:55	11:20 - 13:21	
Duration - Minutes	120	120	120	
Test Date - Acid Gases	18-Nov-25	18-Nov-25	18-Nov-25	
Test Time - Acid Gases	09:11 - 10:11	10:19 - 11:19	11:26 - 12:26	
Duration - Minutes	60	60	60	
Stack Temperature (°C)	150	151	150	150
Average Gas Velocity (m/s)	15.0	14.0	13.5	14.2
Dry Flow Rate (Sm ³ /min)	1286	1198	1166	1217
Moisture (Vol. %)	14.6	15.4	14.8	15.0
Oxygen (Vol. %)(dry basis)	9.92	9.60	9.65	9.72
Carbon Dioxide (Vol. %)(dry basis)	9.92	10.2	10.2	10.1
Particulate (mg/Sm³ @ 11% O₂)	1.01	0.77	0.21	0.66
Hydrogen Fluoride (mg/Sm³ @ 11% O₂)	0.103	0.105	0.094	0.101
Hydrogen Chloride (mg/Sm³ @ 11% O₂)	9.4	61.1	61.1	43.8
Ammonia (mg/Sm³ @ 11% O₂)	0.8	6.0	7.0	4.6
Nitrous Oxide (mg/Sm³ @ 11% O₂)*	6.03	6.74	5.32	6.03
Total Hydrocarbons (mg/Sm³ @ 11% O₂)*	5.12	5.06	4.92	5.03
Hexavalent Chromium (mg/Sm³ @11% O₂)**	0.00021	0.00018	0.00022	0.00021
Trace Metals - Operational Certificate List (mg/Sm³ @ 11% O₂)				
OC Class (Pb, As and Cr)	0.00258	0.00159	0.00111	0.00176
Aluminum (mg/Sm³ @ 11% O₂)	0.01268	0.00861	0.00428	0.00852
Cadmium (mg/Sm³ @ 11% O₂)	0.00010	0.00008	0.00024	0.00014
Lead (mg/Sm³ @ 11% O₂)	0.00116	0.00048	0.00058	0.00074
Mercury (mg/Sm³ @ 11% O₂)	0.00008	0.00005	0.00008	0.000068
Phosphorus (mg/Sm³ @ 11% O₂)	0.00155	0.00383	0.00082	0.00207
Isokinetic Variation (%)	103	104	104	104

All data is corrected to standard conditions (S) of 20 °C, 101.325 kPa (dry) unless otherwise noted.

*N₂O and THC were sampled on November 18, 2025

**Cr+6 was sampled on Nov 20-21, 2025, test times can be found in the appendices. All three runs were found to be below the analytical detection limit for Cr+6, thus the results shown are calculated at 1/2 DL.

Table 4: Unit 1 Trace Metals Emissions (OC Class)

Metal	Test 1 (mg/m ³ @ 11% O ₂)	Test 2 (mg/m ³ @ 11% O ₂)	Test 3 (mg/m ³ @ 11% O ₂)	Average (mg/m ³ @ 11% O ₂)
OC Class				
Pb	0.00116	0.00048	0.00058	0.00074
As	0.00136	0.00032	0.00033	0.00067
Cr	0.00006	0.00080	0.00020	0.00035
Sum of OC Class	0.00258	0.00159	0.00111	0.00176
Other				
Al	0.01268	0.00861	0.00428	0.00852
Cd	0.00010	0.00008	0.00024	0.00014
P	0.00155	0.00383	0.00082	0.00207
Hg	0.00008	0.00005	0.00008	0.00007

All data is corrected to standard conditions (S) of 20 °C, 101.325 kPa (dry) unless otherwise noted.

Table 5: Unit 1 Detailed Trace Metals Emissions

Metal	Test 1 (mg/m ³ @ 11% O ₂)	Test 2 (mg/m ³ @ 11% O ₂)	Test 3 (mg/m ³ @ 11% O ₂)	Average (mg/m ³ @ 11% O ₂)
Pb	0.00116	0.00048	0.00058	0.00074
Sb	0.00255	0.00263	0.00700	0.00406
Cu	0.00032	0.00020	0.00030	0.00027
Mn	0.00062	0.00067	0.00049	0.00059
V	0.00031	0.00032	0.00033	0.00032
Zn	0.01070	0.00845	0.00843	0.00919
As	0.00136	0.00032	0.00033	0.00067
Cr	0.00006	0.00080	0.00020	0.00035
Co	0.00008	0.00008	0.00017	0.00011
Ni	0.00002	0.00016	0.00016	0.00011
Se	0.00046	0.00048	0.00652	0.00249
Te	0.00217	0.00064	0.00066	0.00115
Tl	0.00046	0.00048	0.00049	0.00048
Cd	0.00010	0.00008	0.00024	0.00014
Hg	0.00008	0.00005	0.00008	0.00007

All data is corrected to standard conditions (S) of 20 °C, 101.325 kPa (dry) unless otherwise noted.

Table 6: Unit 1 - Summary of Operating Data

Parameter		Run 1	Run 2	Run 3	Normal
Test Date - Particulate/Metals		17-Nov-25	18-Nov-25	18-Nov-25	
Test Time - Particulate/Metals		12:27 - 14:29	08:53 - 10:55	11:20 - 13:21	
Boiler Steam Production	(kg/h)	35,432	35,073	35,166	37,219
Percentage of normal	(%)	95%	94%	94%	
Boiler Secondary Combustion Zone Temp	(°C)	937	940	952	897
Percentage of normal	(%)	104%	105%	106%	
Rate of refuse fired	(kg/hr)	10,577	10,470	10,497	11,110
Percentage of normal	(%)	95%	94%	94%	
Rate of aux. fuel fired (Natural Gas)	m ³ /hr	0	0	0	226
Percentage of normal (%)	(%)	0%	0%	0%	

*Normal refers to the average operating rate from the previous 30 days

Parameter		Run 1	Run 2	Run 3	Normal
Test Date - Hexavalent Chromium		20-Nov-25	21-Nov-25	21-Nov-25	
Test Time - Hexavalent Chromium		12:00 - 14:05	08:43 - 10:46	11:11 - 13:13	
Boiler Steam Production	(kg/h)	35,241	37,952	36,841	36,985
Percentage of normal	(%)	95%	103%	100%	
Boiler Secondary Combustion Zone Temp	(°C)	915	963	937	901
Percentage of normal	(%)	102%	107%	104%	
Rate of refuse fired	(kg/hr)	10,519	11,329	10,997	11,040
Percentage of normal	(%)	95%	103%	100%	
Rate of aux. fuel fired (Natural Gas)	m ³ /hr	0	0	0	276
Percentage of normal (%)	(%)	0%	0%	0%	

Table 7: Unit 2 Summary of Emission Test Results

Parameter	Run 1	Run 2	Run 3	Average
Test Date - Particulate/Metals	18-Nov-25	19-Nov-25	19-Nov-25	
Test Time - Particulate/Metals	10:55 - 12:56	08:52 - 11:55	12:05 - 14:06	
Duration - Minutes	120	120	120	
Test Date - Acid Gases	19-Nov-25	19-Nov-25	19-Nov-25	
Test Time - Acid Gases	10:24 - 11:24	11:33 - 12:33	12:45 - 13:45	
Duration - Minutes	60	60	60	
Stack Temperature (°C)	149	144	147	147
Average Gas Velocity (m/s)	13.0	12.3	12.3	12.6
Dry Flow Rate (Sm ³ /min)	1130	1052	1084	1089
Moisture (Vol. %)	15.1	16.7	13.9	15.3
Oxygen (Vol. %)(dry basis)	9.76	9.14	9.75	9.55
Carbon Dioxide (Vol. %)(dry basis)	8.91	10.75	10.00	9.89
Particulate (mg/Sm³ @ 11% O₂)	0.82	0.07	0.44	0.44
Hydrogen Fluoride (mg/Sm³ @ 11% O₂)	0.103	0.104	0.112	0.106
Hydrogen Chloride (mg/Sm³ @ 11% O₂)	68.3	54.4	51.6	58.1
Ammonia (mg/Sm³ @ 11% O₂)	6.8	5.3	5.1	5.7
Nitrous Oxide (mg/Sm³ @ 11% O₂)*	-	2.47	5.04	3.76
Total Hydrocarbons (mg/Sm³ @ 11% O₂)	5.50	6.19	5.26	5.65
Trace Metals - Operational Certificate List (mg/Sm³ @ 11% O₂)				
OC Class (Pb, As and Cr)	0.00500	0.00136	0.00165	0.00267
Aluminum (mg/Sm³ @ 11% O₂)	0.00511	0.00180	0.00182	0.00291
Cadmium (mg/Sm³ @ 11% O₂)	0.00018	0.00009	0.00012	0.00013
Lead (mg/Sm³ @ 11% O₂)	0.00051	0.00054	0.00055	0.00053
Mercury (mg/Sm³ @ 11% O₂)	0.00011	0.00004	0.00005	0.00007
Phosphorus (mg/Sm³ @ 11% O₂)	0.00068	0.00936	0.00511	0.00505
Isokinetic Variation (%)	103	105	102	103

All data is corrected to standard conditions (S) of 20 °C, 101.325 kPa (dry) unless otherwise noted.

*N₂O and THC were sampled on November 19, 2025. Unit 2 Run 1 N₂O bag was compromised in transport.

Table 8: Unit 2 Trace Metals Emissions (OC Class)

Metal	Test 1 (mg/m ³ @ 11% O ₂)	Test 2 (mg/m ³ @ 11% O ₂)	Test 3 (mg/m ³ @ 11% O ₂)	Average (mg/m ³ @ 11% O ₂)
OC Class				
Pb	0.0005	0.0005	0.0005	0.00053
As	0.0003	0.0005	0.0004	0.00040
Cr	0.0041	0.0003	0.0007	0.00173
Sum of OC Class	0.0050	0.0014	0.0016	0.00267
Other				
Al	0.00511	0.00180	0.00182	0.00291
Cd	0.00018	0.00009	0.00012	0.00013
P	0.00068	0.00936	0.00511	0.00505
Hg	0.00011	0.00004	0.00005	0.00007

All data is corrected to standard conditions (S) of 20 °C, 101.325 kPa (dry) unless otherwise noted.

Table 9: Unit 2 Detailed Trace Metals Emissions

Metal	Test 1 (mg/m ³ @ 11% O ₂)	Test 2 (mg/m ³ @ 11% O ₂)	Test 3 (mg/m ³ @ 11% O ₂)	Average (mg/m ³ @ 11% O ₂)
Pb	0.00051	0.00054	0.00055	0.00053
Sb	0.00043	0.00090	0.00091	0.00075
Cu	0.00009	0.00009	0.00009	0.00009
Mn	0.00225	0.00022	0.00078	0.00108
V	0.00034	0.00036	0.00036	0.00036
Zn	0.00630	0.00540	0.00682	0.00618
As	0.00034	0.00050	0.00036	0.00040
Cr	0.00415	0.00031	0.00073	0.00173
Co	0.00020	0.00009	0.00052	0.00027
Ni	0.00956	0.00045	0.00018	0.00340
Se	0.00077	0.00054	0.00055	0.00062
Te	0.00068	0.00097	0.00073	0.00079
Tl	0.00051	0.00054	0.00055	0.00053
Cd	0.00018	0.00009	0.00012	0.00013
Hg	0.00011	0.00004	0.00005	0.00007

All data is corrected to standard conditions (S) of 20 °C, 101.325 kPa (dry) unless otherwise noted.

Table 10: Unit 2 - Summary of Operating Data

Parameter		Run 1	Run 2	Run 3	Normal
Test Date - Particulate/Metals		18-Nov-25	19-Nov-25	19-Nov-25	
Test Time - Particulate/Metals		10:55 - 12:56	08:52 - 11:55	12:05 - 14:06	
Boiler Steam Production	(kg/h)	36,008	36,097	37,172	36,547
Percentage of normal	(%)	99%	99%	102%	
Boiler Secondary Combustion Zone Temp	(°C)	882	901	893	876
Percentage of normal	(%)	101%	103%	102%	
Rate of refuse fired	(kg/hr)	10,749	10,776	11,096	10,909
Percentage of normal	(%)	99%	99%	102%	
Rate of aux. fuel fired (Natural Gas)	m³/hr	379	156	163	365
Percentage of normal (%)	(%)	104%	43%	45%	

*Normal refers to the average operating rate from the previous 30 days

Table 11: Unit 3 Summary of Emission Test Results

Parameter	Run 1	Run 2	Run 3	Average
Test Date - Particulate/Metals	19-Nov-25	20-Nov-25	20-Nov-25	
Test Time - Particulate/Metals	11:30 - 13:34	09:05 - 11:06	11:30 - 13:31	
Duration - Minutes	120	120	120	
Test Date - Acid Gases	20-Nov-25	20-Nov-25	20-Nov-25	
Test Time - Acid Gases	09:21 - 10:21	10:30 - 11:30	11:38 - 12:38	
Duration - Minutes	60	60	60	
Stack Temperature (°C)	150	148	147	148
Average Gas Velocity (m/s)	12.8	14.0	14.9	13.9
Dry Flow Rate (Sm ³ /min)	1120	1227	1301	1216
Moisture (Vol. %)	13.9	13.9	14.2	14.0
Oxygen (Vol. %)(dry basis)	9.98	10.2	10.2	10.1
Carbon Dioxide (Vol. %)(dry basis)	10.00	9.58	9.58	9.72
Particulate (mg/Sm³ @ 11% O₂)	0.44	0.57	0.32	0.44
Hydrogen Fluoride (mg/Sm³ @ 11% O₂)	0.098	0.100	0.101	0.100
Hydrogen Chloride (mg/Sm³ @ 11% O₂)	17.9	75.7	119	71.02
Ammonia (mg/Sm³ @ 11% O₂)	4.85	5.40	3.14	4.46
Nitrous Oxide (mg/Sm³ @ 11% O₂)*	5.64	6.96	-	6.30
Total Hydrocarbons (mg/Sm³ @ 11% O₂)**	4.49	4.73	-	4.61
Trace Metals - Operational Certificate List (mg/Sm³ @ 11% O₂)				
OC Class (Pb, As and Cr)	0.00444	0.00132	0.00183	0.00253
Aluminum (mg/Sm³ @ 11% O₂)	0.00017	0.00539	0.00285	0.00280
Cadmium (mg/Sm³ @ 11% O₂)	0.00009	0.00008	0.00020	0.00012
Lead (mg/Sm³ @ 11% O₂)	0.0020	0.0005	0.0005	0.0010
Mercury (mg/Sm³ @ 11% O₂)	0.00004	0.00004	0.00005	0.00005
Phosphorus (mg/Sm³ @ 11% O₂)	0.00385	0.00202	0.00538	0.00375
Isokinetic Variation (%)	103	102	102	103

All data is corrected to standard conditions (S) of 20 °C, 101.325 kPa (dry) unless otherwise noted.

*N₂O was sampled on November 20, 2025. Unit 3 Run 3 bag was compromised in transport.

**THC was sampled on November 20, 2025. The Canister used for sampling Run 3 did not maintain the vacuum required to draw a sample. It was not possible to get a sample.

Table 12: Unit 3 Trace Metals Emissions (OC Class)

Metal	Test 1 (mg/m ³ @ 11% O ₂)	Test 2 (mg/m ³ @ 11% O ₂)	Test 3 (mg/m ³ @ 11% O ₂)	Average (mg/m ³ @ 11% O ₂)
OC Class				
Pb	0.00201	0.00051	0.00047	0.00100
As	0.00028	0.00034	0.00032	0.00031
Cr	0.00215	0.00048	0.00104	0.00122
Sum of OC Class	0.00444	0.00132	0.00183	0.00253
Other				
Al	0.00017	0.00539	0.00285	0.00280
Cd	0.00009	0.00008	0.00020	0.00012
P	0.00385	0.00202	0.00538	0.00375
Hg	0.00004	0.00004	0.00005	0.00005

All data is corrected to standard conditions (S) of 20 °C, 101.325 kPa (dry) unless otherwise noted.

Table 13: Unit 3 Detailed Trace Metals Emissions

Metal	Test 1 (mg/m ³ @ 11% O ₂)	Test 2 (mg/m ³ @ 11% O ₂)	Test 3 (mg/m ³ @ 11% O ₂)	Average (mg/m ³ @ 11% O ₂)
Pb	0.00201	0.00051	0.00047	0.00100
Sb	0.00087	0.00446	0.00079	0.00204
Cu	0.00009	0.00028	0.00036	0.00024
Mn	0.00045	0.00030	0.00082	0.00053
V	0.00035	0.00034	0.00032	0.00033
Zn	0.00248	0.00108	0.00193	0.00183
As	0.00028	0.00034	0.00032	0.00031
Cr	0.00215	0.00048	0.00104	0.00122
Co	0.00009	0.00008	0.00067	0.00028
Ni	0.00114	0.00039	0.00063	0.00072
Se	0.00052	0.00051	0.00047	0.00050
Te	0.00070	0.00532	0.00063	0.00222
Tl	0.00052	0.00497	0.00325	0.00291
Cd	0.00009	0.00008	0.00020	0.00012
Hg	0.00004	0.00004	0.00005	0.00005

All data is corrected to standard conditions (S) of 20 °C, 101.325 kPa (dry) unless otherwise noted.

Table 14: Unit 3 - Summary of Operating Data

Parameter		Run 1	Run 2	Run 3	Normal
Test Date - Particulate/Metals		19-Nov-25	20-Nov-25	20-Nov-25	
Test Time - Particulate/Metals		11:30 - 13:34	09:05 - 11:06	11:30 - 13:31	
Boiler Steam Production	(kg/h)	37,168	36,603	36,604	33,743
Percentage of normal	(%)	110%	108%	108%	
Boiler Secondary Combustion Zone Temp	(°C)	873	875	873	864
Percentage of normal	(%)	101%	101%	101%	
Rate of refuse fired	(kg/hr)	11,095	10,926	10,927	11,562
Percentage of normal	(%)	96%	94%	95%	
Rate of aux. fuel fired (Natural Gas)	m³/hr	0	0	0	369
Percentage of normal (%)	(%)	0%	0%	0%	

*Normal refers to the average operating rate from the previous 30 days

4 DISCUSSION

All Units are in compliance with limits as set out in the OC. This survey meets the fourth quarter requirements and includes the annual test for hexavalent chromium. This year, Unit 1 was chosen for the hexavalent chromium testing.

As stated in Section 2.1, EPA Method 5/29 was modified slightly to accommodate performance based analytical protocols utilized in B.C. for trace metals sampling and analysis. The analytical modification consists of using volumes of recovery reagents different than the method stipulates. To validate (ie performance-based QA) the modification, sample Blanks and all samples were made up to the same volume, so that subtraction of the Blank data, was done on equivalent sample sizes. In addition, special Hg spiking of blank filters and peroxide solutions was conducted. This spiking is referred to as a “matrix spike” and is reported in Appendix B, Quality Control for mercury, where the recovery of spiked mercury was calculated to be an acceptable 85 to 115%. It should be noted that independent front half/back half analysis of all trace metals was conducted for this survey. In addition, individual quartz filter blanks were analyzed for each unit.

Sampling was conducted in accordance with their respective reference methods (EPA 29 except as discussed) and passed all appropriate quality assurance and quality control criteria. None of the sample points on any of the three units were outside of the allowable +/- 10% for isokinetic rate. The N₂O sample bags from “Unit 2 Run 1” and “Unit 3 Run 3” were compromised in transport from the laboratories sample reception to the analytical location and an analytical result was not possible. The N₂O results presented for Units 2 and 3 are 2-run averages. Similarly, one of the canisters did not maintain vacuum and was equalized with atmospheric pressure when a sample was attempted. Therefore, Unit 3 VOC results are an average of 2 runs.

During the monitoring, there were no environmental observations made that would impact the validity of the test program. The weather was normal with light rain and wind on one day, but otherwise dry. All sampling was conducted/supervised by certified emission

testing personnel, using calibrated source sampling equipment and quality-controlled reagents. It is therefore stated that the survey and this report complies with MV's WTEF compliance testing requirements for this fourth survey in 2025.