



**A.Lanfranco
& Associates Inc.**

Environmental Consultants

Prepared for

METRO VANCOUVER

Metrotower III

**4515 Central Boulevard
Burnaby, BC V5H 0C6**

Waste-to-Energy Facility

Emissions Test Report

Third Quarter 2022 Survey

Operational Certificate 107051

Prepared by Shawn Harrington

Issued: October 11, 2022

CERTIFICATION

The field monitoring for this survey was conducted by certified stack test technicians as required by the British Columbia Ministry of Environment (BC MOE) Field Sampling Manual.

The field crew consisted of:

Mr. S. Harrington (certified), Mr. C. Lanfranco (certified), Mr. S. Ferguson (certified), Mr. L. Agassiz (certified) and Mr. L. Forrer.

The report was prepared by Mr. L. Agassiz using reporting principles and guidelines generally acceptable to Metro Vancouver (MV).

The field crew and A. Lanfranco and Associates Inc. certify that the test methods used were BC MOE/MV approved reference methods for the parameters investigated.

Report reviewed by:



Mark Lanfranco, CST
President | Owner

TEST PROGRAM ORGANIZATION

Primary Stakeholders:

Mr. Brent Kirkpatrick
Metro Vancouver
Lead Senior Engineer
Email: brent.kirkpatrick@metrovancover.org
Tel: (604) 451-6623

Ms. Nicole Victor
Covanta Burnaby Renewable Energy
Facility Manager
Email: nvictor@covanta.com
Tel: (604) 521-1025 ext.211

Project Manager:

Mr. Mark Lanfranco
President | Owner
A. Lanfranco and Associates Inc.
101 – 9488 189 St
Surrey, BC Canada V4N 4W7
Tel: (604) 881-2582
Email: mark.lanfranco@alanfranco.com

Sampling Crew:

Mr. S. Harrington - A. Lanfranco and Associates Inc.
Mr. D. Sampson - A. Lanfranco and Associates Inc.
Mr. J. Gibbs - A. Lanfranco and Associates Inc.
Mr. M. Goods – A. Lanfranco and Associates Inc.
Mr. L. Forrer – A. Lanfranco and Associates Inc.

Table of Contents

SUMMARY	1
1 INTRODUCTION	2
2 METHODOLOGY	3
2.1 Sampling and Analytical Methods	3
2.2 Method Modifications	8
2.3 Calculations	9
2.3.1 Parameter Concentration Calculations	9
2.3.2 Isokinetic Variation Calculations	11
2.3.3 Volumetric Flowrate Calculations	13
3 DETAILED TEST RESULTS	14
4 DISCUSSION	20

List of Tables

Table 1: Summary Comparison of Emissions Test Results with Limits	1
Table 2: Reference Methods	3
Table 3: Unit 1 Summary of Emission Test Results.....	14
Table 4: Unit 1 Trace Metals Emissions (OC Class).....	15
Table 5: Unit 1 Detailed Trace Metals Emissions	15
Table 6: Unit 2 Summary of Emission Test Results.....	16
Table 7: Unit 2 Trace Metals Emissions (OC Class).....	17
Table 8: Unit 2 Detailed Trace Metals Emissions	17
Table 9: Unit 3 Summary of Emission Test Results.....	18
Table 10: Unit 3 Trace Metals Emissions (OC Class).....	19
Table 11: Unit 3 Detailed Trace Metals Emissions	19

SUMMARY

The following table displays the emission results from the three units located at Metro Vancouver's Waste-To-Energy Facility (WTEF) as well as the current emission limits as defined by the Operational Certificate (OC) issued by BC Ministry of Environment & Climate Change Strategy. This compliance survey represents the third quarter of 2022.

Table 1: Summary Comparison of Emissions Test Results with Limits

Parameter	Limit	Unit 1	Unit 2	Unit 3	Facility Average
Test Date		28-29 July 2022	18-19 July 2022	7-8 Sept. 2022	
Particulate (mg/m ³ @ 11% O ₂)	9.0	0.22	0.23	4.72	1.72
Hydrogen Fluoride (mg/m ³ @ 11% O ₂)	1.0	0.004	0.005	0.015	0.008
Trace Metals - OC Class (mg/m ³ @ 11% O ₂)					
Lead (Pb)	-	0.0012	0.0018	0.0079	0.0037
Arsenic (As)	-	0.0003	0.0014	0.0005	0.0007
Chromium (Cr)	-	0.0012	0.0016	0.0159	0.0062
OC Class Sum (Pb, As and Cr)	0.064	0.0028	0.0048	0.0242	0.0106
Mercury (mg/m ³ @ 11% O ₂)	0.02	0.0001	0.00004	0.00007	0.00006
Cadmium (mg/m ³ @ 11% O ₂)	0.007	0.0001	0.0001	0.0014	0.0005

All data is corrected to standard conditions (S) of 20 °C, 101.325 kPa (dry) unless otherwise noted.

Compared to previous testing in 2022, most results were similar; however, there was variability found for Unit 3. Most notably, particulate matter and trace metals were elevated. Despite said variability, the results are within the expected range based on normal operations and are not considered significant.

1 INTRODUCTION

Metro Vancouver (MV) commissioned an emission survey at the Waste-To-Energy Facility (WTEF) in Burnaby BC, as required by the provincially approved Operational Certificate (OC). This report documents the results of a survey on Units 1, 2 and 3 for the third survey of four for the year 2022. This survey includes filterable particulate matter, trace metals, mercury (Hg), hydrogen fluoride (HF), ammonia (NH₃) and nitrous oxide (N₂O). A. Lanfranco and Associates Inc., of Surrey, B.C., conducted the sampling program on behalf of MV. The sampling program consisted of, but was not limited to, the planning, execution, analysis, and reporting of three emission sources located at the WTEF.

This report includes a comparison of emission results to limits established in the OC, detailed emission results, a brief outline of methods employed, equipment used, and a discussion of the survey. All supporting data and appendices are presented under separate cover.

The individual sources that were monitored for compliance are identified as Unit 1, Unit 2 and Unit 3 which represent the three distinct processing lines at the WTEF. The three boilers are identified as discharge E300670 in the operational certificate.

Sampling was conducted on July 18-19, 28-29, and September 7-8, 2022. The testing spanned several weeks due to process curtailments associated with air pollution control (APC) equipment maintenance on Units 1 and 3. None of the replicates per unit took place more than two days apart however.

2 METHODOLOGY

All services provided by A. Lanfranco and Associates Inc. were conducted in accordance with approved reference methods as issued by:

- Metro Vancouver (MV)
- BC Ministry of Environment & Climate Change Strategy (BC MOE)
- Environment Canada (EC)
- US Environmental Protection Agency (EPA)

2.1 Sampling and Analytical Methods

The following table lists the test methods used for the different parameters measured. The subsequent paragraphs briefly describe each method.

Table 2: Reference Methods

<u>Parameter</u>	<u>Reference Method</u>
Sample and Velocity traverse points	EPS 1/RM/8 A Determination of Sampling Site and Traverse Points
Velocity and flowrate	EPS 1/RM/8 B Determination of Stack Gas Velocity and Volumetric Flow Rate (Type S Pitot Tube)
Gas molecular weight (O ₂ /CO ₂)	EPS 1/RM/8 C Determination of Molecular Weight by Gas Analysis
Flue gas Moisture	EPS 1/RM/8 D Determination of Moisture Content
Particulate Matter	EPS 1/RM/8 E Determination of Particulate Matter Emissions from Stationary Sources
Trace Metals with Mercury	EPA Method 29 Determination of Metals Emissions from Stationary Sources
Hydrogen Fluoride (HF)	EPS1/RM/1 Reference Method for Source Testing: Measurement of Releases of Gaseous Hydrogen Chloride from Stationary Sources
Nitrous Oxide (N ₂ O)	N/A
Ammonia (NH ₃)	EPA Method CTM 027

Sampling Site and Traverse Points

Primary: EPS 1/RM/8 Method A

Supporting: EPA Method 1

This method is designed to aid in the representative measurement of pollutant emissions and/or total volumetric flow rate from a stationary source. A measurement site where the effluent stream is flowing in a known direction is selected, and the cross-section of the stack is divided into a number of equal areas. Traverse points are then located within each of these equal areas.

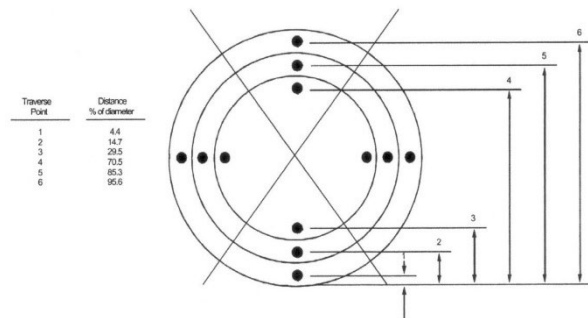

Figure 1. Example showing circular stack cross section divided into 12 equal areas, with location of traverse points.

Stack Gas Velocity and Volumetric Flow Rate

Primary: EPS 1/RM/8 Method B

Supporting: EPA Method 2

The average gas velocity in a stack or duct is determined from the gas density and from the measurement of velocity pressure with an S-type pitot tube. A standard pitot tube may be used where plugging of the tube openings due to particulate matter and/or moisture is not likely to occur. Stack gas volumetric flow rate is determined from measurements of stack gas velocity, temperature, absolute pressure, dry gas composition, moisture content, and stack diameter.

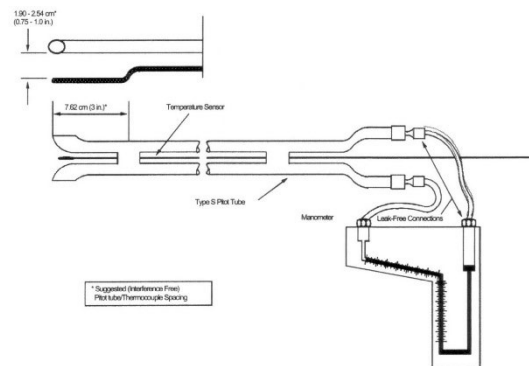

Figure 2. Type S Pitot Tube Manometer Assembly

Molecular Weight by Gas Analysis

Primary: EPS 1/RM/8 Method C
Supporting: EPA Method 3

An integrated or grab sample is extracted from a single point in the gas stream and analyzed for its components using a Fyrite analyzer, a gas chromatograph, or calibrated continuous analyzers.

Moisture Content

Primary: EPS 1/RM/8 Method D
Supporting: EPA Method 4

A gas sample is extracted from a single point in the enclosed gas stream being sampled. The moisture is condensed, and its weight measured. This weight, together with the volume of gas sampled, enables the stack gas moisture content to be calculated.

Particulate Matter

Primary: EPS 1/RM/8 Method E
Supporting: EPA Method 5

Particulate matter is withdrawn isokinetically from a number of sampling or traverse points in an enclosed gas stream. The particulate sample is collected in the nozzle, probe, and on a glass fibre filter, all maintained at a temperature of $120 \pm 14^{\circ}\text{C}$ or such other temperature as is necessary to prevent blinding of the filter from condensation. The particulate weight is determined gravimetrically after removal of uncombined water. Simultaneous determinations of the gas stream moisture content, velocity, temperature, and molecular weight allow calculations of the particulate concentration and the particulate mass emission or release rate to be made.

Trace Metal

Primary: EPA Method 29 (modified)

This method is used in conjunction with the above Method 5. A stack sample is withdrawn isokinetically from the source. Particulate emissions are collected in the probe and on a heated filter, and gaseous emissions are then collected in an aqueous acidic solution of hydrogen peroxide (analyzed for all metals including Hg) and an aqueous acidic solution of potassium permanganate (analyzed only for Hg). The recovered samples are digested, and appropriate fractions are analyzed for Hg by cold vapour atomic absorption spectroscopy (CVAAS). The remaining trace metals are analyzed with inductively coupled argon plasma emission spectroscopy (ICAP), atomic absorption spectroscopy (AAS) and graphite furnace atomic absorption spectroscopy (GFAAS). Figure 3 displays the sample train and its configuration.

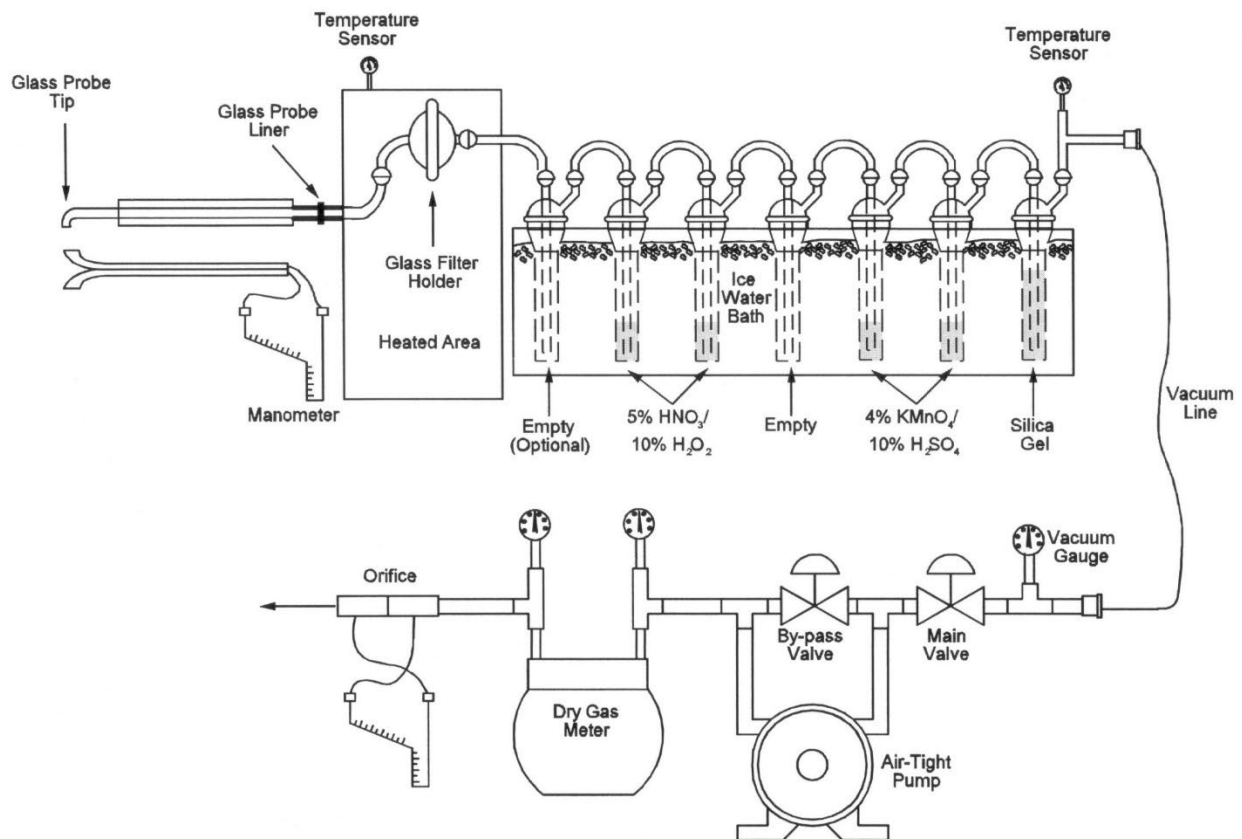

Figure 3. Particulate / Trace Metals Sampling Train

Hydrogen Fluoride

Primary: EPS 1/RM/1

Supporting: BC Method 7176106 & 7066101

HF is sampled in a four-impinger train consisting of two impingers containing distilled/deionized H₂O, one empty impinger, and a fourth containing silica gel. A sample of the stack gas is extracted from a single point near the centre of the stack over the sample duration at a constant rate. The collected samples are measured for F by ion chromatography at ALS Environmental in Burnaby, BC.

N₂O

Primary: N/A

Three N₂O samples were collected from each source using Viasensor G200 Medical Grade gas analyser, factory calibrated to Nitrous Oxide. The flue gas was introduced to the G200 after passing through a soda lime filter to remove CO₂. Multiple readings were taken over a one hour period, these readings were averaged on the analyzer and recorded on the data sheet.

Ammonia

Primary: EPA Method CTM-027

The absorbing solution in the first two impingers is 0.1 N H₂SO₄ and the triplicate samples were extracted at a constant rate for 60-minute durations. The collected samples are analyzed at Element Laboratories in Surrey, BC

Method Modifications

Three minor method modifications were instituted for this work.

1. Reagent blanks for metals trains were made to the same volumes as all samples. In other words, exactly 100 ml of the various reagents used to recover samples was NOT done, as some sample components (probe washing for example) required more than 100 ml to adequately clean and rinse the probe. Instead, sample recovery was conducted with however much rinsing was deemed adequate. In the laboratory, the blanks and samples were made up with the appropriate reagent so that all samples and blanks were the same volume.
2. Filter and residue weighing were not conducted with the six-hour interval technique. Instead, the sample filters and beakers were conditioned with cooling and desiccation and then weighed on two separate laboratory scales after 24 hours. Duplicate or triplicate Blank samples were carried through the gravimetric analysis, and the sample results were adjusted with the Blank data to determine the net filter and probe wash residue weight gain. This is the Environment Canada approved modified approach for weighing probe wash residue.
3. For the purposes of calculating a result, all parameters were given the value of $\frac{1}{2}$ the detection limit when the analysis yielded 'non-detect' results.

All results are expressed using the metric system and corrected to standard conditions of 20 °C and 101.325 kPa, dry gas (unless otherwise noted).

2.2 Calculations

The following sections show the equations and define the variables that were used for this survey. The equations are organized in three sections. Equations 1-11 were used to calculate parameter concentration at standard conditions on a dry basis. Equations 12-26 were used to sample within the $100 \pm 10\%$ isokinetic variation and to confirm that sampling meets this isokinetic variation threshold. Equations 27-29 were used to calculate the volumetric flowrate of the stack flue gas.

2.2.1 Parameter Concentration Calculations

$$c = \frac{m}{V_{std}} \quad \text{Equation 1}$$

$$m_{part} = m_{filter} + m_{pw} \quad \text{Equation 2}$$

$$m_i = m_{ana,i} - m_{blank} \quad \text{Equation 3}$$

$$m_{HF} = \frac{20.006}{18.998} (m_F - m_{blank}) / 1000 \quad \text{Equation 4}$$

$$V_{std} = \frac{V_{std(imp)}}{35.315} \quad \text{Equation 5}$$

$$V_{std(imp)} = \frac{V_{samp} \times y \times P_m \times (T_{std} + 459.67)}{P_{std} \times (T_{m(ave)} + 459.67)} \quad \text{Equation 6}$$

$$V_{samp} = V_{final} - V_{init} \quad \text{Equation 7}$$

$$P_m = P_B + \frac{\Delta H_{ave}}{13.6} \quad \text{Equation 8}$$

$$\Delta H_{ave} = \frac{1}{n} \sum_{i=1}^n \Delta H_{i(act)}, \text{ where } n = \text{the number of points} \quad \text{Equation 9}$$

$$OC = \frac{20.9 - \%O_{2c}}{20.9 - \%O_{2m}} \quad \text{Equation 10}$$

$$\%O_{2m} = \frac{1}{n} \sum_{i=1}^n \%O_{2i}, \text{ where } n = \text{the number of } O_2 \text{ measurements} \quad \text{Equation 11}$$

Where,

c	= Parameter concentration
m	= Parameter mass
m_i	= Net analytical mass (mg, ng, or μg)
$m_{ana,i}$	= Analytical mass (mg, ng, or μg)
m_{blank}	= Blank analytical mass (mg, ng, or μg)
m_{part}	= Total particulate mass (mg)
m_{filter}	= Net particulate gain from filter (mg)
m_{pw}	= Net particulate gain from probe wash (mg)
m_{HF}	= Net mass of HF (mg)
m_F	= Net mass of F (μg)
$V_{std(imp)}$	= Sample volume at standard conditions (ft^3)
V_{std}	= Sample volume at standard conditions (m^3)
V_{samp}	= Sample volume at actual conditions (ft^3)
V_{final}	= Final gas meter reading (ft^3)
V_{init}	= Initial gas meter reading (ft^3)
T_{std}	= Standard temperature (68 °F)
T_m	= Gas meter temperature (°F)
$T_{m(ave)}$	= Average gas meter temperature (°F)
P_m	= Absolute meter pressure (inches of Hg)
P_B	= Barometric pressure (inches of Hg)
P_{std}	= Standard barometric pressure (29.92 inches of Hg)
ΔH_{ave}	= Average of individual point orifice pressures (inches of H_2O)
$\Delta H_{i(act)}$	= Individual recorded point orifice pressures (inches of H_2O)
OC	= Oxygen correction factor (dimensionless)
$\%O_{2c}$	= Oxygen concentration to correct to (% dry basis)
$\%O_{2i}$	= Individual oxygen measurements (% dry basis)
$\%O_{2m}$	= Average measured stack gas oxygen concentration (% dry basis)

Equation 1 is the general concentration calculation used for all parameters. The mass, m , is the net analytic mass for the given parameter. For particulate, m is the sum of the mass contributed from probe washing and filter particulate.

For trace metals and Hg, m is the blank corrected (Equation 3) analytical result (Appendix 1) for each metals species and run. If the analytical result was below the detection limit, half of the detection limit (DL) was used for m in Equation 1.

The HF concentration was calculated from analytic results. Equation 4 was used to convert the F mass to HF, and this result was used as m in equation 1. As with the trace metals, half the detection limit was substituted for results that were non-detectable.

2.2.2 Isokinetic Variation Calculations

$$\Delta H_i = \frac{2.62 \times 10^7 \times c_p \times A_n \times (1 - B_{wo}) \times M_D \times (T_m + 459.67) \times \Delta p_i}{k_o \times M_w \times (T_{Stk} + 459.67)} \quad \text{Equation 12}$$

$$R_m = 85.49 \times c_p \times \sqrt{\Delta p_i} \times \sqrt{\frac{(T_{Stk_i} + 459.67)}{M_w \times P_B}} \times 60 \times A_n \times \frac{(T_{m_i} + 459.67) \times (1 - B_{wo})}{(T_{Stk_i} + 459.67) \times y} \quad \text{Equation 13}$$

$$A_n = \pi \left(\frac{d_n}{24} \right)^2 \quad \text{Equation 14}$$

$$M_w = M_D \times (1 - B_{wo}) + 18 \times B_{wo} \quad \text{Equation 15}$$

$$M_D = 0.44 \times \%CO_2 + 0.32 \times \%O_2 + 0.28 \times (100 - \%CO_2 - \%O_2) \quad \text{Equation 16}$$

$$T_{Stk} = \frac{1}{n} \sum_{i=1}^n T_{Stk_i}, \text{ where } n = \text{the number of points} \quad \text{Equation 17}$$

$$B_{wo} = \frac{V_{cond}}{V_{cond} + V_{std(imp)}} \quad \text{Equation 18}$$

$$V_{cond} = 0.04707 \times V_{gain} \quad \text{Equation 19}$$

$$Iso = \frac{1}{n} \sum_{i=1}^n Iso_i, \text{ where } n = \text{the number of points} \quad \text{Equation 20}$$

$$Iso_i = \frac{v_{nzi}}{v_i} \quad \text{Equation 21}$$

$$v_i = 85.49 \times c_p \times \sqrt{\Delta p_i} \times \sqrt{\frac{(T_{Stk_i} + 459.67)}{(P_{Stk} \times M_w)}} \quad \text{Equation 22}$$

$$v_{nzi} = \frac{(V_i - V_{i-1}) \times y \times (T_{Stk_i} + 459.67) \times (P_B + \frac{\Delta H_{i(act)}}{13.6})}{A_n \times t_i \times 60 \times (T_{m(i)} + 459.67) \times P_{Stk} \times (1 - B_{wo})} \quad \text{Equation 23}$$

$$P_{stk} = P_B + \frac{P_g}{13.6} \quad \text{Equation 24}$$

$$v_{stk} = \frac{1}{n} \sum_{i=1}^n v_i, \text{ where } n = \text{the number of points} \quad \text{Equation 25}$$

$$v_{nz} = \frac{1}{n} \sum_{i=1}^n v_{nzi}, \text{ where } n = \text{the number of points} \quad \text{Equation 26}$$

Where,

A_n	= Nozzle area (ft ²)
d_n	= Diameter of nozzle (inches)
c_p	= Pitot coefficient (dimensionless)
Δp_i	= Individual point differential pressures (inches of H ₂ O)
T_{stk}	= Average flue gas temperature (°F), second subscript <i>i</i> , indicates individual point measurements
T_m	= Average gas meter temperature (°F), second subscript <i>i</i> , indicates individual point measurements
k_o	= Gas meter calibration constant (dimensionless)
y	= Gas meter calibration factor (dimensionless)
$\Delta H_{i(act)}$	= Calculated individual point orifice pressures (inches of H ₂ O)
P_g	= Stack Static pressure (inches of H ₂ O)
P_{stk}	= Absolute stack pressure (inches of Hg)
M_w	= Wet gas molecular weight (g/gmol)
M_D	= Dry gas molecular weight (g/gmol)
%CO ₂	= Stack gas carbon dioxide concentration (% dry basis)
%O ₂	= Stack gas oxygen concentration (% dry basis)
B_{wo}	= Stack gas water vapour, proportion by volume
V_i	= Gas meter reading at individual point(ft ³)
t_i	= Sample time at each point (minutes)
V_{cond}	= Total volume of water vapor collected, corrected to standard conditions (ft ³)
V_{gain}	= Condensate gain of impinger contents (mL)
P_{std}	= Standard pressure (29.92 inches of Hg)
v_{stk}	= Average flue gas velocity (ft/sec)
v_i	= Individual point flue gas velocity (ft/sec)
v_{nz}	= Average velocity at nozzle(ft/sec)
v_{nzi}	= Individual point velocity at nozzle(ft/sec)
ISO_i	= Individual point isokinetic variation (%)
ISO	= Average isokinetic variation (%)
R_m	= Isokinetic sampling rate (ft ³ /min)

2.2.3 Volumetric Flowrate Calculations

$$Q_S = Q_A \times \frac{(T_{Std} + 459.67)}{(T_{Stk} + 459.67)} \times \frac{P_{Stk}}{P_{Std}} \quad \text{Equation 27}$$

$$Q_A = \frac{v_{stk} \times 60 \times A_{stk}}{35.315} \quad \text{Equation 28}$$

$$A_{stk} = \pi \left(\frac{d}{24} \right)^2 \quad \text{Equation 29}$$

Where,

- Q_A = Actual flowrate (Am^3/min)
 Q_S = Flowrate (m^3/min) at standard conditions on a dry basis
 A_{stk} = Area of stack (ft^2)
 d = Diameter of stack (inches)

3 DETAILED TEST RESULTS

The results of stack emissions were calculated using a “STACK” computer program developed by A. Lanfranco and Associates for BC MOE requirements.

Tables 3-11 present the detailed results of all emissions parameters tested for each of the units. Additional data and the computer outputs can be found in the accompanying Appendices.

Table 3: Unit 1 Summary of Emission Test Results

Parameter	Run 1	Run 2	Run 3	Average
Test Date - Particulate/Metals	28-Jul-22	28-Jul-22	29-Jul-22	
Test Time - Particulate/Metals	09:26 - 11:28	12:22 - 14:24	08:50 - 10:53	
Duration - Minutes	120	120	120	
Test Date - Acid Gases	29-Jul-22	29-Jul-22	29-Jul-22	
Test Time - Acid Gases	09:24 - 10:24	10:42 - 11:42	11:54 - 12:54	
Duration - Minutes	60	60	60	
Stack Temperature (°C)	154	154	156	155
Average Gas Velocity (m/s)	14.0	14.1	14.6	14.3
Dry Flow Rate (m ³ /min)	1215	1220	1247	1227
Moisture (Vol. %)	13.7	13.7	14.5	14.0
Oxygen (Vol. %)(dry basis)	10.3	10.1	10.0	10.13
Carbon Dioxide (Vol. %)(dry basis)	9.8	9.6	9.8	9.7
Particulate (mg/m³ @ 11% O₂)	0.22	0.28	0.16	0.22
Hydrogen Fluoride (mg/m³ @ 11% O₂)	0.008	0.002	0.002	0.004
Ammonia (mg/m³ @ 11% O₂)	2.11	2.31	1.08	1.83
Nitrous Oxide (mg/m³ @ 11% O₂)*	1.59	1.07	2.72	1.79
Trace Metals - Operational Certificate List (mg/m³ @ 11% O₂)				
OC Class (Pb, As and Cr)	0.00320	0.00279	0.00227	0.00275
Aluminum (mg/m³ @ 11% O₂)	0.01348	0.01968	0.00477	0.01264
Cadmium (mg/m³ @ 11% O₂)	0.00008	0.00008	0.00008	0.00008
Lead (mg/m³ @ 11% O₂)	0.00096	0.00170	0.00103	0.00123
Mercury (mg/m³ @ 11% O₂)	0.00006	0.00005	0.00004	0.00005
Phosphorus (mg/m³ @ 11% O₂)	0.00303	0.00267	0.00064	0.00211
Isokinetic Variation (%)	102	101	103	102

*N₂O was sampled on July 29, 2022

All data is corrected to standard conditions (S) of 20 °C, 101.325 kPa (dry) unless otherwise noted.

Table 4: Unit 1 Trace Metals Emissions (OC Class)

Metal	Test 1 (mg/m ³ @ 11% O ₂)	Test 2 (mg/m ³ @ 11% O ₂)	Test 3 (mg/m ³ @ 11% O ₂)	Average (mg/m ³ @ 11% O ₂)
OC Class				
Pb	0.00096	0.00170	0.00103	0.00123
As	0.00034	0.00033	0.00032	0.00033
Cr	0.00191	0.00075	0.00092	0.00119
Sum of OC Class	0.00320	0.00279	0.00227	0.00275
Other				
Al	0.01348	0.01968	0.00477	0.01264
Cd	0.00008	0.00008	0.00008	0.00008
P	0.00303	0.00267	0.00064	0.00211
Hg	0.00006	0.00005	0.00004	0.00005

All data is corrected to standard conditions (S) of 20 °C, 101.325 kPa (dry) unless otherwise noted.

Table 5: Unit 1 Detailed Trace Metals Emissions

Metal	Test 1 (mg/m ³ @ 11% O ₂)	Test 2 (mg/m ³ @ 11% O ₂)	Test 3 (mg/m ³ @ 11% O ₂)	Average (mg/m ³ @ 11% O ₂)
Pb	0.00096	0.00170	0.00103	0.00123
Sb	0.00143	0.00142	0.00079	0.00121
Cu	0.00040	0.00153	0.00041	0.00078
Mn	0.00135	0.00050	0.00083	0.00089
V	0.00034	0.00033	0.00032	0.00033
Zn	0.00566	0.00664	0.00311	0.00514
As	0.00034	0.00033	0.00032	0.00033
Cr	0.00191	0.00075	0.00092	0.00119
Co	0.00008	0.00008	0.00023	0.00013
Ni	0.00236	0.00170	0.00219	0.00208
Se	0.00051	0.00160	0.00048	0.00086
Te	0.00182	0.00100	0.00257	0.00180
Tl	0.00051	0.00199	0.00056	0.00102
Cd	0.00008	0.00008	0.00008	0.00008
Hg	0.00006	0.00005	0.00004	0.00005

All data is corrected to standard conditions (S) of 20 °C, 101.325 kPa (dry) unless otherwise noted.

Table 6: Unit 2 Summary of Emission Test Results

Parameter	Run 1	Run 2	Run 3	Average
Test Date - Particulate/Metals	18-Jul-22	19-Jul-22	19-Jul-22	
Test Time - Particulate/Metals	12:25 - 14:28	09:15 - 11:18	11:55 - 13:57	
Duration - Minutes	120	120	120	
Test Date - Acid Gases	19-Jul-22	19-Jul-22	19-Jul-22	
Test Time - Acid Gases	10:23 - 11:23	11:45 - 12:45	13:02 - 14:02	
Duration - Minutes	60	60	60	
Stack Temperature (°C)	146	138	144	143
Average Gas Velocity (m/s)	13.7	13.5	13.2	13.4
Dry Flow Rate (m ³ /min)	1202	1204	1175	1193
Moisture (Vol. %)	14.1	14.9	13.3	14.1
Oxygen (Vol. %)(dry basis)	10.38	10.63	11.00	10.67
Carbon Dioxide (Vol. %)(dry basis)	9.9	9.0	8.8	9.2
Particulate (mg/m³ @ 11% O₂)	0.03	0.33	0.33	0.23
Hydrogen Fluoride (mg/m³ @ 11% O₂)	0.005	0.005	0.006	0.005
Ammonia (mg/m³ @ 11% O₂)	0.072	0.317	0.263	0.217
Nitrous Oxide (mg/m³ @ 11% O₂)*	2.66	1.36	1.65	1.89
Trace Metals - Operational Certificate List (mg/m³ @ 11% O₂)				
OC Class (Pb, As and Cr)	0.00765	0.00507	0.00172	0.00481
Aluminum (mg/m³ @ 11% O₂)	0.00577	0.01245	0.02064	0.01295
Cadmium (mg/m³ @ 11% O₂)	0.00018	0.00010	0.00017	0.00015
Lead (mg/m³ @ 11% O₂)	0.00437	0.00057	0.00058	0.00184
Mercury (mg/m³ @ 11% O₂)	0.00004	0.00005	0.00004	0.00004
Phosphorus (mg/m³ @ 11% O₂)	0.00087	0.00096	0.00097	0.00094
Isokinetic Variation (%)	101	100	98.2	99.5

*N₂O was sampled on July 19, 2022

All data is corrected to standard conditions (S) of 20 °C, 101.325 kPa (dry) unless otherwise noted.

Table 7: Unit 2 Trace Metals Emissions (OC Class)

Metal	Test 1 (mg/m ³ @ 11% O ₂)	Test 2 (mg/m ³ @ 11% O ₂)	Test 3 (mg/m ³ @ 11% O ₂)	Average (mg/m ³ @ 11% O ₂)
OC Class				
Pb	0.0044	0.0006	0.0006	0.0018
As	0.0005	0.0030	0.0006	0.0014
Cr	0.0028	0.0015	0.0005	0.0016
Sum of OC Class	0.0077	0.0051	0.0017	0.0048
Other				
Al	0.00577	0.01245	0.02064	0.0130
Cd	0.00018	0.00010	0.00017	0.0001
P	0.00087	0.00096	0.00097	0.0009
Hg	0.00004	0.00005	0.00004	0.0000

All data is corrected to standard conditions (S) of 20 °C, 101.325 kPa (dry) unless otherwise noted.

Table 8: Unit 2 Detailed Trace Metals Emissions

Metal	Test 1 (mg/m ³ @ 11% O ₂)	Test 2 (mg/m ³ @ 11% O ₂)	Test 3 (mg/m ³ @ 11% O ₂)	Average (mg/m ³ @ 11% O ₂)
Pb	0.00437	0.00057	0.00058	0.00184
Sb	0.00149	0.00096	0.00097	0.00114
Cu	0.00119	0.00010	0.00010	0.00046
Mn	0.00056	0.00092	0.00051	0.00066
V	0.00035	0.00038	0.00039	0.00037
Zn	0.00241	0.00747	0.00265	0.00418
As	0.00052	0.00303	0.00058	0.00138
Cr	0.00276	0.00147	0.00055	0.00159
Co	0.00009	0.00010	0.00009	0.00009
Ni	0.00364	0.00153	0.00088	0.00202
Se	0.00052	0.00057	0.00058	0.00056
Te	0.00269	0.00077	0.00160	0.00169
Tl	0.00052	0.00057	0.00058	0.00056
Cd	0.00018	0.00010	0.00017	0.00015
Hg	0.00004	0.00005	0.00004	0.00004

All data is corrected to standard conditions (S) of 20 °C, 101.325 kPa (dry) unless otherwise noted.

Table 9: Unit 3 Summary of Emission Test Results

Parameter	Run 1	Run 2	Run 3	Average
Test Date - Particulate/Metals	7-Sep-22	8-Sep-22	8-Sep-22	
Test Time - Particulate/Metals	11:34 - 13:37	08:20 - 10:23	10:45 - 12:48	
Duration - Minutes	120	120	120	
Test Date - Acid Gases	8-Sep-22	8-Sep-22	8-Sep-22	
Test Time - Acid Gases	09:07-10:07	10:31-11:31	11:42-12:42	
Duration - Minutes	60	60	60	
Stack Temperature (°C)	151	151	154	152
Average Gas Velocity (m/s)	12.6	12.6	12.6	12.6
Dry Flow Rate (m ³ /min)	1073	1029	1019	1040
Moisture (Vol. %)	16.2	19.6	19.7	18.5
Oxygen (Vol. %)(dry basis)	9.58	10.18	9.65	9.80
Carbon Dioxide (Vol. %)(dry basis)	9.4	9.5	10.1	9.7
Particulate (mg/m³ @ 11% O₂)	4.08	5.23	4.86	4.72
Hydrogen Fluoride (mg/m³ @ 11% O₂)	0.016	0.014	0.015	0.015
Ammonia (mg/m³ @ 11% O₂)	2.72	2.69	2.09	2.50
Nitrous Oxide (mg/m³ @ 11% O₂)*	2.46	2.14	2.25	2.28
Trace Metals - Operational Certificate List (mg/m³ @ 11% O₂)				
OC Class (Pb, As and Cr)	0.03929	0.01797	0.01541	0.02422
Aluminum (mg/m³ @ 11% O₂)	0.02724	0.11732	0.01080	0.05179
Cadmium (mg/m³ @ 11% O₂)	0.00122	0.00147	0.00145	0.00138
Lead (mg/m³ @ 11% O₂)	0.00750	0.00788	0.00834	0.00791
Mercury (mg/m³ @ 11% O₂)	0.00008	0.00006	0.00009	0.00007
Phosphorus (mg/m³ @ 11% O₂)	0.00536	0.01596	0.00225	0.00785
Isokinetic Variation (%)	91.7	96.2	96.4	94.8

*N₂O was sampled on Sept.8, 2022.

All data is corrected to standard conditions (S) of 20 °C, 101.325 kPa (dry) unless otherwise noted.

Table 10: Unit 3 Trace Metals Emissions (OC Class)

Metal	Test 1 (mg/m ³ @ 11% O ₂)	Test 2 (mg/m ³ @ 11% O ₂)	Test 3 (mg/m ³ @ 11% O ₂)	Average (mg/m ³ @ 11% O ₂)
OC Class				
Pb	0.00750	0.00788	0.00834	0.00791
As	0.00045	0.00047	0.00045	0.00046
Cr	0.03134	0.00962	0.00661	0.01586
Sum of OC Class	0.03929	0.01797	0.01541	0.02422
Other				
Al	0.02724	0.11732	0.01080	0.0518
Cd	0.00122	0.00147	0.00145	0.0014
P	0.00536	0.01596	0.00225	0.0079
Hg	0.00008	0.00006	0.00009	0.0001

All data is corrected to standard conditions (S) of 20°C, 101.325 kPa (dry) unless otherwise noted.

Table 11: Unit 3 Detailed Trace Metals Emissions

Metal	Test 1 (mg/m ³ @ 11% O ₂)	Test 2 (mg/m ³ @ 11% O ₂)	Test 3 (mg/m ³ @ 11% O ₂)	Average (mg/m ³ @ 11% O ₂)
Pb	0.00750	0.00788	0.00834	0.00791
Sb	0.00112	0.00117	0.00112	0.00114
Cu	0.00407	0.00316	0.00630	0.00451
Mn	0.00313	0.00108	0.00432	0.00284
V	0.00045	0.00047	0.00045	0.00046
Zn	0.07184	0.07391	0.12434	0.09003
As	0.00045	0.00047	0.00045	0.00046
Cr	0.03134	0.00962	0.00661	0.01586
Co	0.00050	0.00052	0.00072	0.00058
Ni	0.01540	0.00610	0.00540	0.00897
Se	0.00109	0.00070	0.00079	0.00086
Te	0.00089	0.00094	0.00090	0.00091
Tl	0.00067	0.00070	0.00067	0.00068
Cd	0.00122	0.00147	0.00145	0.00138
Hg	0.00008	0.00006	0.00009	0.00007

All data is corrected to standard conditions (S) of 20°C, 101.325 kPa (dry) unless otherwise noted.

4 DISCUSSION

All Units are in compliance with limits as set out in the OC.

During routine maintenance prior to emissions testing, the facility discovered several compromised fabric filters in the baghouses of Units 1 and 3. In the interest of testing during conditions representative of normal, testing was postponed at these locations until replacement bags could be installed.

As stated in Section 2.1, EPA Method 5/29 was modified slightly to accommodate performance based analytical protocols utilized in B.C. for trace metals sampling and analysis. The analytical modification consists of using volumes of recovery reagents different than the method stipulates. In order to validate (ie performance-based QA) the modification, sample Blanks and all samples were made up to the same volume, so that subtraction of the Blank data, was done on equivalent sample sizes. In addition, special Hg spiking of blank filters and peroxide solutions was conducted. This spiking is referred to as a “matrix spike” and is reported in Appendix B, Quality Control for mercury, where the recovery of spiked mercury was calculated to be an acceptable 85 to 115%. It should be noted that independent front half/back half analysis of all trace metals was conducted for this survey. In addition, individual quartz filter blanks were analyzed for each unit.

Sampling was conducted in accordance with their respective reference methods (EPA 29 except as discussed) and passed all appropriate quality assurance and quality control criteria. None of the sample points on any of the three units were outside of the allowable +/- 10% for isokinetic rate.

All sampling was conducted/supervised by certified emission testing personnel, using calibrated source sampling equipment and quality-controlled reagents. It is therefore stated that the survey and this report complies with the MV’s WTEF compliance testing requirements for this third survey in 2022.