



WASTE DISCHARGE PERMIT NO. SC-100071-FSA

Pursuant to:

Greater Vancouver Sewerage & Drainage District Sewer Use Bylaw No. 299, 2007 (as amended)
and the BC Environmental Management Act, S.B.C. 2003, c.53

Issued to:

Hain Celestial Canada, ULC
(the "Permittee")

To Authorize:

the discharge of Wastewater to Sewer from
a food processing facility

Located at

1638 Derwent Way, Delta, BC V3M 6R9

Effective Period:

The terms and conditions set out in the Permit apply to the existing or planned works on
May 02, 2019

All previous versions of this Waste Discharge Permit are hereby rescinded and rendered null and void.

Issued: July 31, 1997
Amended: May 02, 2019

Grant McGillivray
Deputy Sewage Control Manager

GREATER VANCOUVER SEWERAGE & DRAINAGE DISTRICT

SCHEDULE A

This Schedule sets out requirements for the quantity and quality of the discharge to Sewer.

1. AUTHORIZED RATE OF DISCHARGE

The Permittee shall not exceed the following:

Sample Point: 1

- Maximum daily discharge flow rate: **370.00 m³/d**
- Maximum instantaneous peak flow rate: **10.50 L/s**

2. AUTHORIZED DISCHARGE CRITERIA

- a) The Permittee shall not discharge Restricted Waste or other Waste, as defined in the Bylaw, including but not limited to the following (regardless of sample type):

| Parameter | Authorized Limit | Notes |
|------------------------|---------------------|-------|
| pH | 5.5 - 10.5 pH Units | |
| Total Suspended Solids | 600 mg/L | |
| Total Oil & Grease | 150 mg/L | |

- b) The Permittee shall not discharge Restricted Waste or other Waste, as defined in the Bylaw, with the following exceptions (regardless of sample type):

| Parameter | Authorized Limit | Notes |
|---------------------------|------------------|-------|
| Biochemical Oxygen Demand | No Limit | |

- c) The Permittee shall not discharge Prohibited Waste, Storm Water or Uncontaminated Water, as defined in the bylaw.
- d) The Permittee shall not discharge Hazardous Waste, or effluent from the treatment of Hazardous Waste which exceeds the Effluent Standards for Hazardous Waste Facilities, as stipulated in Schedule 1.2, Column 3, of the BC Environmental Management Act Hazardous Waste Regulation.

Issued: July 31, 1997
Amended: May 02, 2019

Grant McGillivray
Deputy Sewage Control Manager

Waste Discharge Permit No. SC-100071-FSA

GREATER VANCOUVER SEWERAGE & DRAINAGE DISTRICT

SCHEDULE B

This Schedule sets out requirements and locations for the approved sample points, waste sources, and works and procedures to treat and/or control the discharges to Sewer.

1. SAMPLE POINTS, WASTE SOURCES, WORKS & PROCEDURES

SAMPLE POINT: 1

This sample point is considered to be a point of discharge to Sewer. The approved sample point location is described and is illustrated in the photo(s) below.

Description: The T-section on the grey pipe from the 20 ft container that enters the underground interceptor in the parking lot adjacent to the main plant entrance.

Source: All Plant Sources

Manual cleaning and sterilization of food preparation equipment and fryer using foaming and sanitizing equipment and acidic and caustic cleaning solutions.

Clean- in-Place system for the spiral oven and spiral freezer using acidic and caustic cleaning solutions

Cleaning the floors and drains in food preparation areas

Type: Continuous

| Works and Procedures | Completion Date |
|--|------------------------|
| Programmable logic controller | Completed |
| Screened floor drains and collection system | Completed |
| Underground interceptor with baffles, level control and pumps | Completed |
| 2000 L reaction tank #1 with acid injection, mixer and pH sensor | Completed |
| 5000 L equalization tank | Completed |
| 1000 L reaction tank #3 with acid and caustic injection, mixer, pH sensor and alarm | Completed |
| Automatic drain valve for a recirculation loop for non compliant wastewater | Completed |
| Continuous pH adjustment | Completed |
| Continuous pH monitoring and recording | Completed |
| Continuous flow monitoring and recording | Completed |
| Clean and maintain the underground interceptor, 2000 L reaction tank and 5000 L equalization tanks as needed to remove sediment, fat, oil and grease | Completed |
| Clean, calibrate and maintain the pH probes and flow sensor as needed | Completed |
| Good operating practices | Completed |

Issued: July 31, 1997

Amended: May 02, 2019

Grant McGillivray

Deputy Sewerage Control Manager

Waste Discharge Permit No. SC-100071-FSA

GREATER VANCOUVER SEWERAGE & DRAINAGE DISTRICT

SCHEDULE B

Photograph of Sample Point 1:



The "T" fitting on the grey pipe

Issued: July 31, 1997
Amended: May 02, 2019

Waste Discharge Permit No. SC-100071-FSA

Grant McGillivray
Deputy Sewage Control Manager

GREATER VANCOUVER SEWERAGE & DRAINAGE DISTRICT

SCHEDULE B

2. SITE PLAN(S)

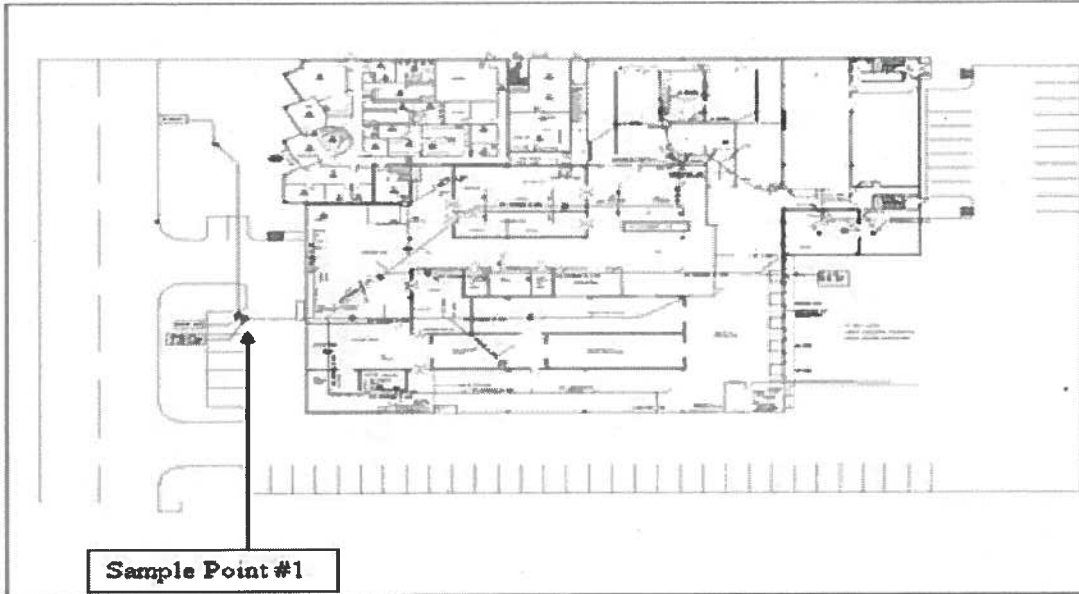

Issued: July 31, 1997
Amended: May 02, 2019

Waste Discharge Permit No. SC-100071-FSA

Grant McGillivray
Deputy Sewage Control Manager

GREATER VANCOUVER SEWERAGE & DRAINAGE DISTRICT

SCHEDULE B

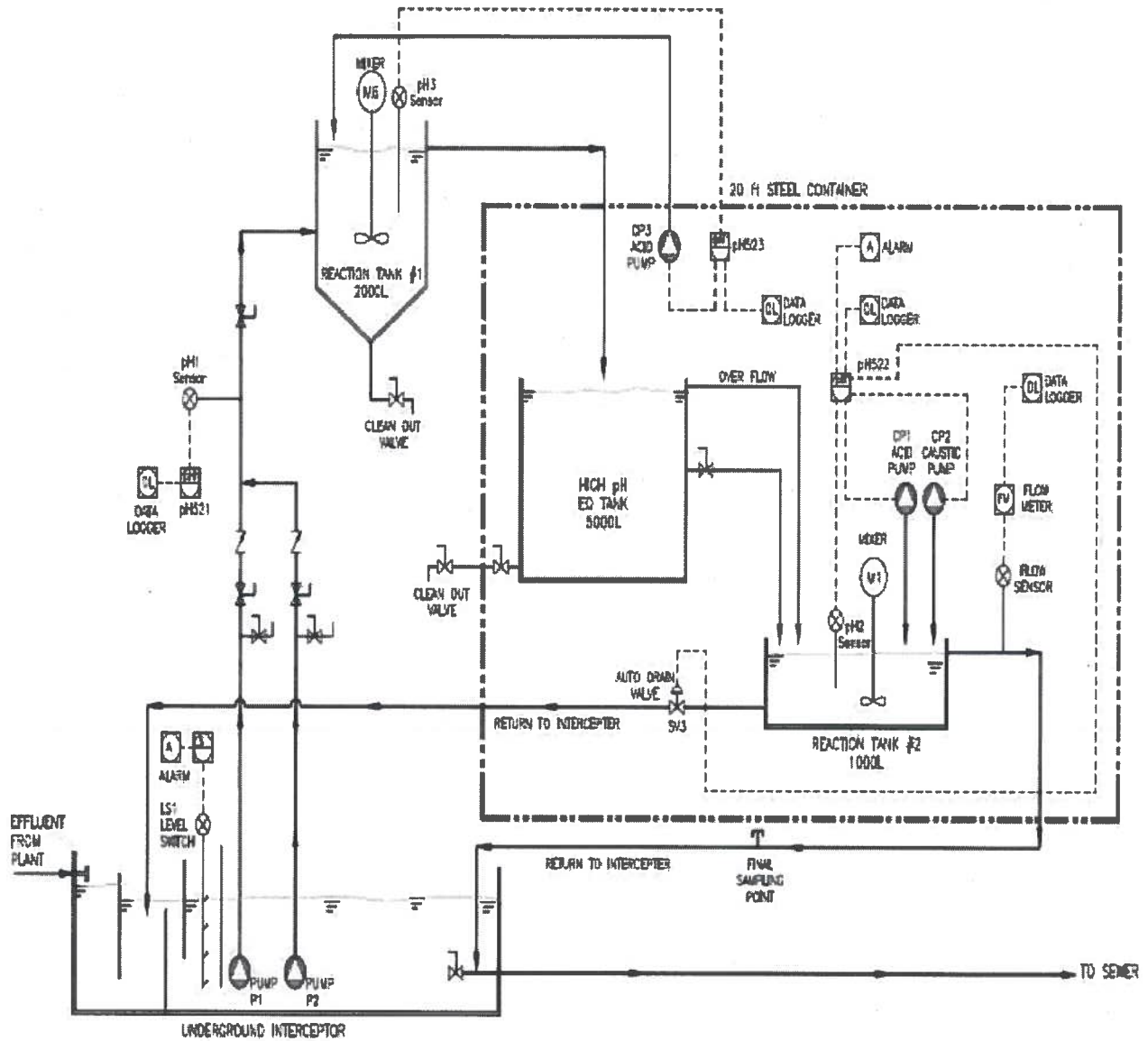

Issued: July 31, 1997
 Amended: May 02, 2019

Waste Discharge Permit No. SC-100071-FSA

Grant McGillivray
 Grant McGillivray
 Deputy Sewage Control Manager

GREATER VANCOUVER SEWERAGE & DRAINAGE DISTRICT

SCHEDULE C

This Schedule sets out standard conditions and requirements for emergency procedures.

1. STANDARD CONDITIONS

- a) Except as otherwise provided in this Permit, all terms, conditions and definitions stipulated in the Bylaw shall apply to this Permit.
- b) Pursuant to the Bylaw, the Sewage Control Manager (the Manager) may amend the terms and conditions of this Permit.
- c) All records required by this permit shall be kept available for a minimum period of one year.

2. WORKS AND PROCEDURES

- a) All authorized works, procedures and requirements shall be employed at all times during any discharge to sewer. As applicable, all such works shall be inspected and calibrated regularly and maintained in good working condition.
- b) The Manager may require that additional works be installed if the existing works do not provide an acceptable level of treatment. The Manager must authorize new works or alterations to existing works. The Manager must authorize new waste sources.

3. NOTIFICATION PROCEDURES

The Permittee shall immediately report to Metro Vancouver at 604-643-8488 (24 hours):

- a) Spills with the potential to be discharged to the Sanitary Sewer.
- b) Failure of authorized works or conditions and/or failure to carry out authorized procedures that will or have the potential to result in a Permit limit being exceeded.
- c) Discharge pH less than 2 or greater than 12.5.

4. BY-PASSES

The discharge of Wastes that by-pass any authorized works or is not in accordance with procedures designated by the Permit is prohibited, unless prior authorization of the Manager is obtained.

5. DISCHARGE MONITORING

- a) All sampling and sample handling of wastewater discharges, including sample containers, storage, preservation and hold time requirements shall be carried out in accordance with all prescribed requirements stated within the latest edition of the "British Columbia Environmental Laboratory Manual" published by the Ministry of Environment, Province of British Columbia or "Standard Methods for the Examination of Water and Wastewater" published by the American Public Health Association, or an alternate standard authorized by the Manager.
- b) With the exception of pH measurements, all samples shall be analyzed by an independent, ISO/IEC 17025:2005 accredited laboratory unless otherwise authorized by the Manager.

Issued: July 31, 1997
Amended: May 02, 2019

Grant McGillivray
Deputy Sewage Control Manager

Waste Discharge Permit No. SC-100071-FSA

GREATER VANCOUVER SEWERAGE & DRAINAGE DISTRICT

SCHEDULE C

- c) Laboratories used by the Permittee must also be accredited by the Canadian Association for Laboratory Accreditation and/or the Standards Council of Canada for all parameters analyzed and must participate in relevant proficiency testing programs for each parameter.
- d) Any changes in method or location of monitoring must be authorized by the Manager.
- e) Additional monitoring and/or reporting shall be undertaken by the Permittee when required by the Manager.

Issued: July 31, 1997
Amended: May 02, 2019

Grant McGillivray
Deputy Sewage Control Manager

Waste Discharge Permit No. SC-100071-FSA

GREATER VANCOUVER SEWERAGE & DRAINAGE DISTRICT

SCHEDULE D

This Schedule sets out the requirements for the monitoring of the discharge to Sewer.

DISCHARGE SAMPLING AND ANALYSES

1. FLOW MEASUREMENTS

The Permittee shall measure or estimate the discharge flow to sanitary sewer during each month of operation using the method(s) authorized in Schedule B and record for reporting purposes the following:

- Total discharge volume (m³) for the month for sample point(s) 1
- Number of days of discharge to sewer during the month for sample point(s) 1
- Maximum daily discharge flow rate (m³/d) during the month for sample point(s) 1
- Maximum instantaneous flow rate (L/s) during the month for sample point(s) 1

2. CONTINUOUS MEASUREMENTS

The Permittee shall continuously measure the discharge pH during the period of discharge to sewer for sample point(s) 1 and record for reporting purposes the following:

- The total number of hours of discharge below the authorized pH range and the total number of hours of discharge above the authorized pH range during each month of operation.
- Total number of hours of discharge during the month.

3. SAMPLING PROGRAM

Continuous Discharge Sampling:

The Permittee shall record for reporting purposes for each sample the following:

- Sample date
- Sample collection time or sample collection start and stop time(s) if applicable
- Total daily discharge volume (m³) on the date of sampling

Issued: July 31, 1997
Amended: May 02, 2019

Grant McGillivray
Deputy Sewage Control Manager

Waste Discharge Permit No. SC-100071-FSA

GREATER VANCOUVER SEWERAGE & DRAINAGE DISTRICT

SCHEDULE D

SAMPLE POINT: 1

Continuous Discharges:

On one normal operating day once per month collect 1 set of composite samples and analyze for:

- Biochemical Oxygen Demand
- Total Suspended Solids

On one normal operating day once per month collect 1 set of grab samples and analyze for:

- pH
- Total Oil & Grease

Grab sample pH analysis must be conducted immediately upon sampling.

Unless otherwise specified, composite samples shall consist of equal portions of grab samples, collected at a frequency of at least one per hour during discharge to sewer.

If composite sampling is specified, grab samples shall be taken during the period of composite sampling unless noted otherwise in this Schedule.

Unless otherwise specified, all samples should be taken during normal operations.

Issued: July 31, 1997
Amended: May 02, 2019

Grant McGillivray
Deputy Sewage Control Manager

Waste Discharge Permit No. SC-100071-FSA

GREATER VANCOUVER SEWERAGE & DRAINAGE DISTRICT

SCHEDULE E

This Schedule sets out reporting requirements for this Permit.

1. REPORTING REQUIREMENTS

By July 31, 2019 and quarterly thereafter for the term of this permit:

The Permittee shall submit a report detailing the results of the discharge sampling and analyses program, as specified, for the previous calendar quarter including lab reports. This information shall be submitted electronically using the supplied password-enabled web based application.

Should a violation of any term or condition of the Permit be noted, the report shall include a summary of the investigation into the cause of the violation and the corrective actions taken or proposed to prevent future violations. This does not preclude the immediate notification requirements specified in Schedule C.

2. ADDITIONAL REPORTING

| Report Type | Requirements | Due Date | Frequency |
|-----------------------|--|-----------------|----------------------|
| Equipment Maintenance | Submit the cleaning and inspection records for the underground interceptor and the above ground tanks described in Schedule B. Submit the cleaning, calibration and maintenance records for the pH and flow sensors described in Schedule B. This information shall be submitted electronically using the supplied password-enabled web based application. | July 31, 2019 | Quarterly thereafter |

Issued: July 31, 1997
Amended: May 02, 2019

Grant McGillivray
Deputy Sewage Control Manager

Waste Discharge Permit No. SC-100071-FSA

